

## Ventilating Series General Catalogue



- Ventilating Fans
- Air Moving Equipment
- Air Curtains

# Index

Index	01
Why is Ventilation Necessary	03
Recommended Application	05
Ventilation Schedule	07



## VENTILATING FAN

Ceiling Mount Type	09
Industrial Type	13

## AIR MOVING EQUIPMENT

Introduction	19
Low-noise Type Cabinet Fans (In-line Fans)	20
Plastic Type Cabinet Fans	24
Mini Sirocco Fans	26
Recessed Light Fan	30
Centrifugal Fans	32
Adjustable Pitch Axial Flow Fans	36



## AIR CURTAINS

Introduction	41
Air Curtains	42

## ACCESSORIES

Pipe Hood	47
Vent Cap	48

Memo	49
Recent AME Significant Projects	50



# Why is Ventilation Necessary?

Homes designed and buildings in recent years are more airtight and energy efficient than in the past. To obtain this airtight design, house wraps, newly designed windows and doors, sealing caulks and other insulating materials are used to create a seal for optimum energy efficiency. But pollutants retained in airtight buildings can be hazardous to their occupants and jeopardize structural integrity. Proper mechanical ventilation design can address poor indoor air quality, while retaining energy efficiency.

## Biological Pollutants

Biological pollutants, including mold, mildew, pollen, dust mites, pet dander, viruses and bacteria, are found in all homes commonly. Accumulation of these pollutants may cause hazardous effects to the



occupants and building structure. Most biological pollutants can flourish in a humid, moist environment. Moisture accumulates in the room leads the growth of mold and mildew. Proper ventilation is used to combat this accumulation.

### Volatile Organic Compounds (VOC)

Volatile Organic Compounds are carbon-based compounds that easily evaporate. These types of gases are released from building materials, carpets, furniture and many other solid household items. They can ultimately sensitize certain people to react to them. Prolonged exposure to concentrated amounts of them may cause immune-system damage, headaches, dizziness, nausea and muscle spasms. Proper ventilation is necessary for maintaining a

pleasant environment.

### Ways to Improve Indoor Air Quality

The first step to improve indoor air quality should reduce or remove the source of the pollutants. Unfortunately, indoor pollutants are virtually impossible to eliminate completely, creating the need for a second step – ventilation. Ventilation is divided into “Natural Ventilation” and “Mechanical Ventilation”.

Natural ventilation is neither consistent nor reliable since it relies heavily on wind and weather conditions. Mechanical ventilation removes stale, moist, polluted air and replaces it with fresh outside air by using a fan.

# Recommended Application of Ceiling Mount Ventilating Fan & Low-noise Type Cabinet Fan (In-line Fan)

## Residence



 Exhaust

 Intake

 Low Noise Type Cabinet Fan (In-line Fan)

 Ceiling Mount Ventilating Fan

 Intake Grille



 Exhaust Grille



 Vent Cap / Pipe hood

---

## Commercial Office



- 
-  Intake Grille
  -  Exhaust Grille

-  Low Noise Type Cabinet Fan (In-line Fan)
-  Ceiling Mount Ventilating Fan

# Ventilation Schedule

## THE NUMBER OF VENTILATING FANS REQUIRED

(A) : Room size (M<sup>3</sup>) x (B) : Necessary frequency of Ventilation per Hour

(C) : Air Volume of Ventilating Fan (M<sup>3</sup>).

**Note:**

Room size (A) is calculated from the following equation:

(A) = Floor area (sq. m. or sq. ft.) x Room height (m or ft.)

If the room height exceeds 4 meters (13 feet), use 4 meters (13 feet) in the calculation regardless of the actual room height.

Values for (B) in the above equation are given in the table on the below. These values were empirically found by the research scientists.

Value for (C) in the above equation are given in our catalogs.

	A	B		A	B
Hotel	Dance hall	8	Photo studio	Darkroom	10
	Dining hall	8		School	Laboratory
	Kitchen	15	Cooking room		15
	Hallway	5	Auditorium		6
	Toilet	5	Gymnasium		8
	Lavatory	10	Toilet		12
	Boiler room	20	Library		6
	Laundry	15	Classroom		6
Hospital Operating room	Waiting room	10	Theater		Auditorium
	Clinic	6		Hallway	6
	Ward	6		Smoking room	12
	Bathroom	5		Toilet	10
	Office	6		Projection booth	20
	Restaurant	8		Workroom	6
	Kitchen	15	Telephone switch board room	6	
	Gallery	5	Factory	Painting room	20
	Toilet	10		Dynamo room and substation	20
	Boiler room	10		Condenser room	15
	Laundry	15		Office	6
	Operating room	15	Restaurant and snack bar	Restaurant	6
	Disinfecting room	12		Kitchen	20
	Room for the patients receiving medical treatment for the diseases of respiratory organs	10	Office building	Office	6
	Public toilet	20		Waiting room	10
Vessel	Passenger room	6		Conference room	12
				Display room	10
Home	Kitchen	15	Toilet	10	
	Parlor	6	Others	Rooms where poisonous or inflammable gas is produced	more than 20
	Living room	6			
Library	Reading room	6			
A : Type of room			B: Necessary frequency of ventilation per ho		





# VENTILATING FAN



Ceiling Mount Type

09



Industrial Type

13



FV-24CMU1  
FV-24CMD1  
FV-24CMH1  
FV-27CMD1  
FV-27CMH1

These fans are installed in the ceiling connected with ductwork, by which indoor air is exhausted either through the roof or the exterior wall. Since they are mainly mounted inside the ceiling, the interior is not damaged.

Being acceptable by Hong Kong Fire Service Department

\* Relevant requirement for installed area should be fulfilled.



DUCT-TYPE CEILING MOUNT VENTILATING FAN

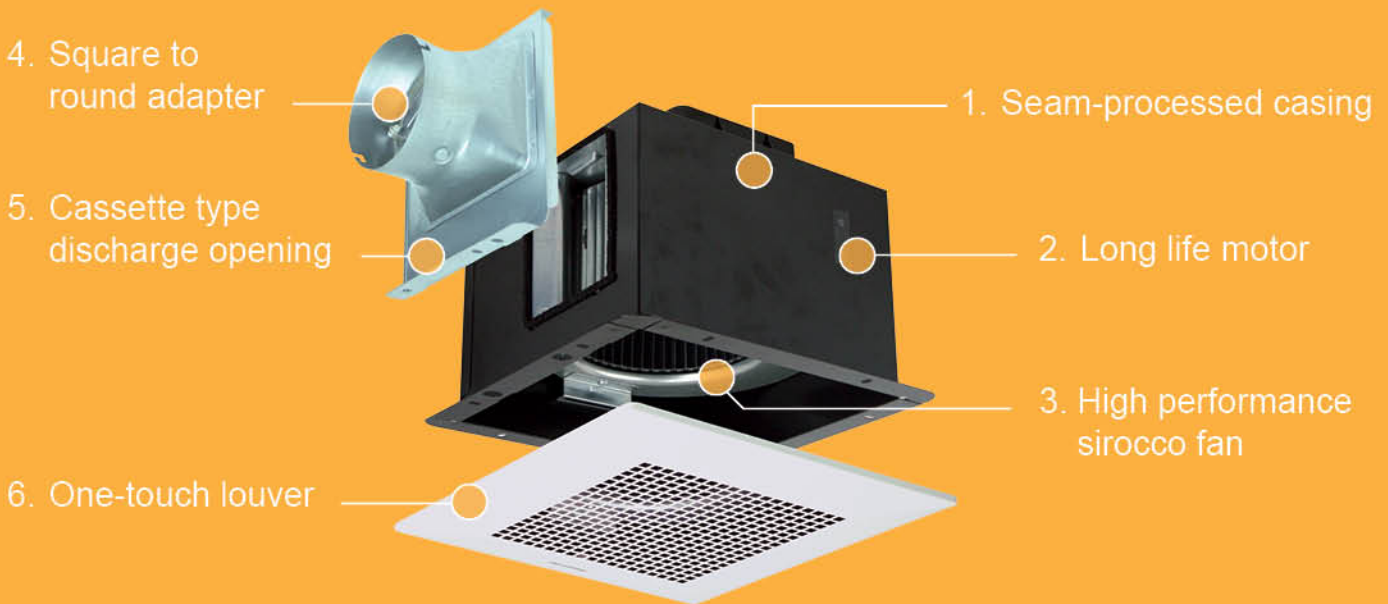

**1** Panasonic's unique seam-processed casing ensures strength and hermetic sealing.

**2** The long life motor designed to withstand continuous operation is adopted in all models.

**3** By adoption of high performance sirocco-fan reduces the noise level and sustains static pressure induced by long duct.

**4** Adoption of detachable square to round adapter facilitating duct connection work.

**5** Installation and removal of the main body can be performed easily even after completion of the duct work. Since the main body can easily be removed to the inside of the room, the access door is not required.

**6** Installation and removal of the louver can be performed by finger touch, thereby permitting maintenance can be performed easily.

Specifications

Main Components and Material

Components	Frame	Blade	Louver
Material	Steel	Steel	Steel

Model	Phase	Rating Voltage	Air Volume		Power Consumption [W]	Fan Speed [R.P.M]	Noise [dB(A)]	Weight [Kg]	Current [A]	Duct Diameter [mm]	Blade Diameter [mm]	Installation Size [mm]
			[CMH]	[l/s]								
FV-24CMU1	1	AC 220V/ 50Hz	100	28	11	495	26	3.8	0.06	100	158	240sq.
FV-24CMD1			165	46	18	670	33					
FV-24CMH1			210	58	25	800	38					
FV-27CMD1			300	83	26	520	32	5.6	0.12			
FV-27CMH1			400	111	43	620	38					

Dimensions

- FV-24CMU1 • FV-24CMD1 • FV-24CMH1

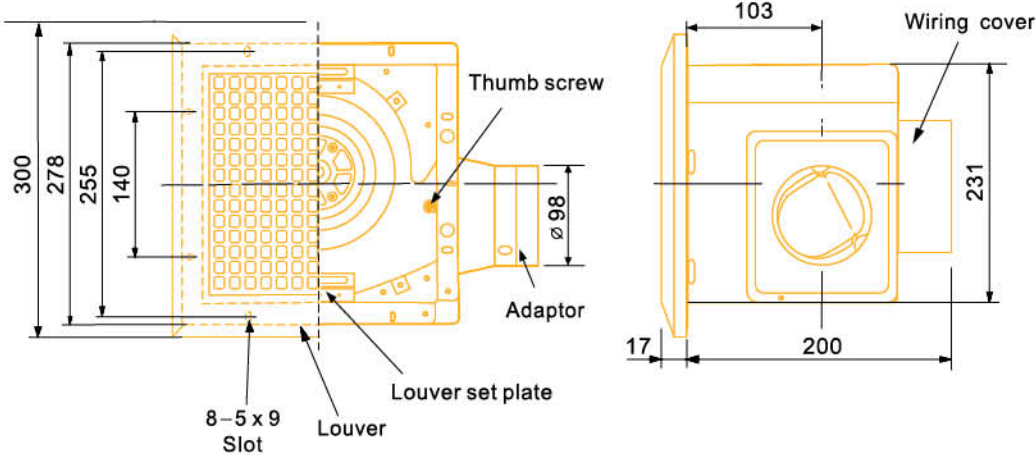

\* Dimensions (mm)

Model	Installation Hole Size	Duct Diameter
FV-24CUM1 / FV-24CMD1 / FV-24CMH1	□ 240mm / 9.5 inch	Ø 100mm / 4 inch

- FV-27CMD1 • FV-27CMH1

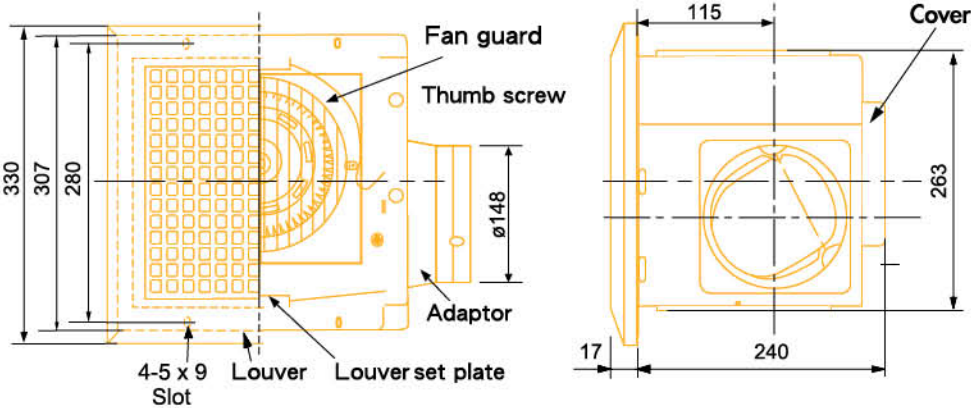

\* Dimensions (mm)

Model	Installation Hole Size	Duct Diameter
FV-27CMD1 / FV-27CMH1	□ 270mm / 10.6 inch	Ø 150mm / 6 inch

### Performance Data

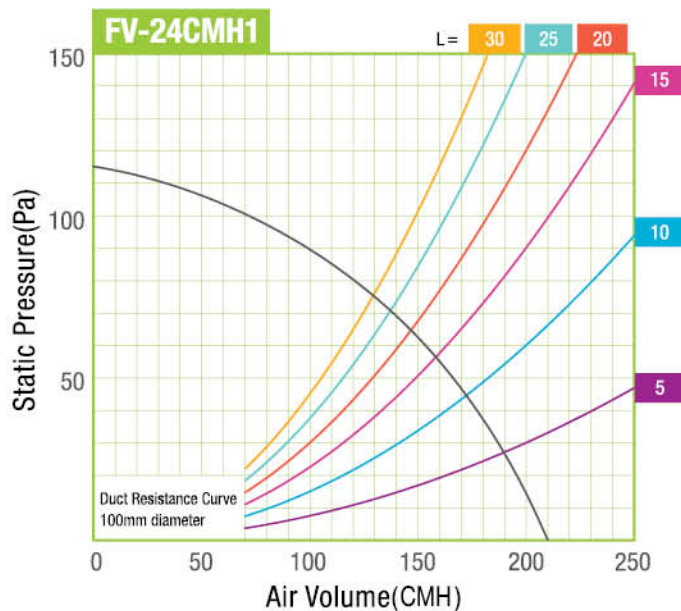
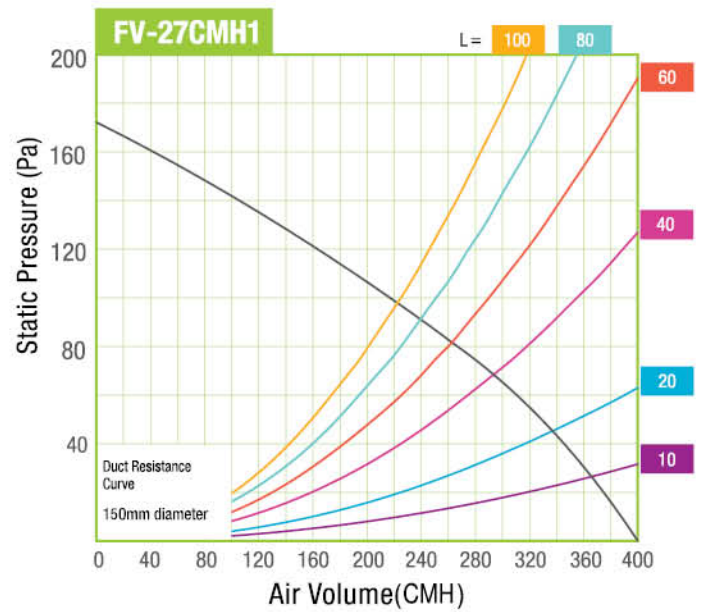
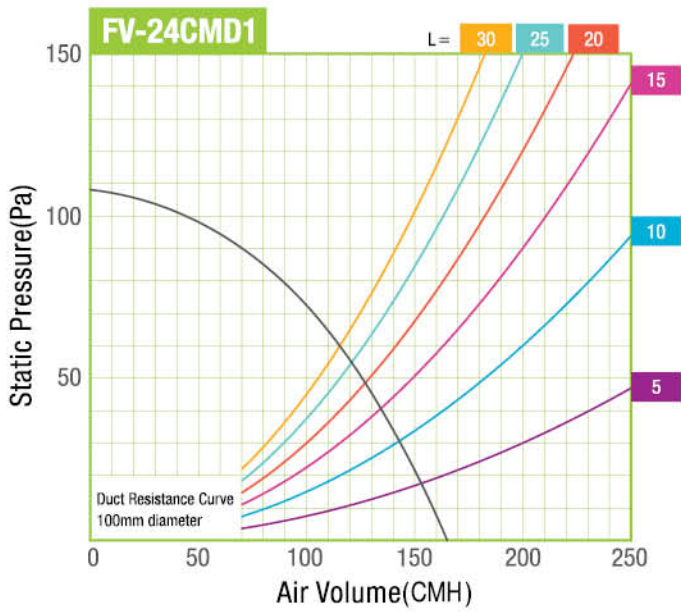
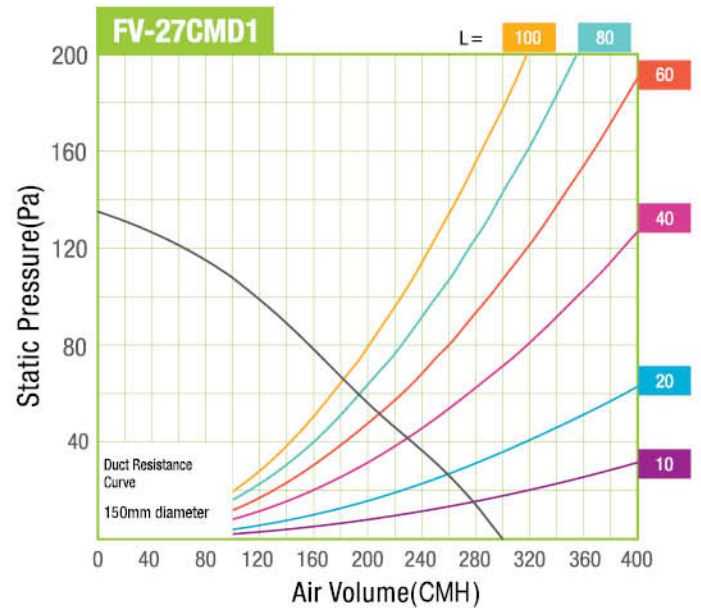
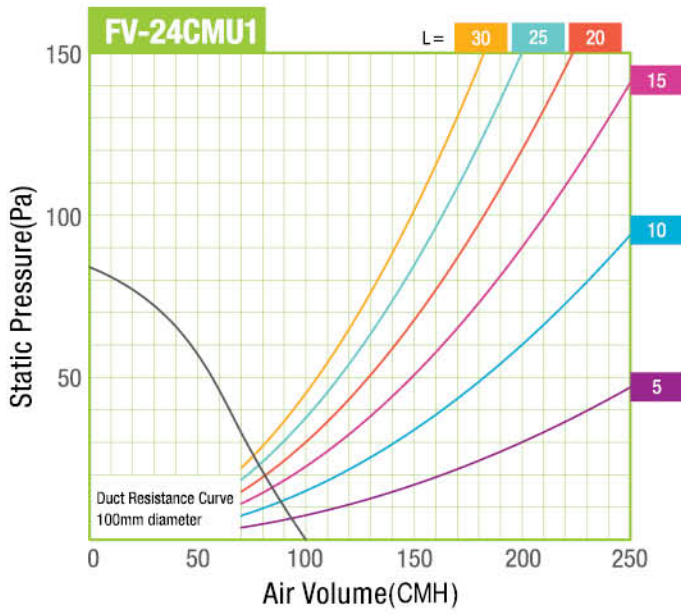

Maintenance Method

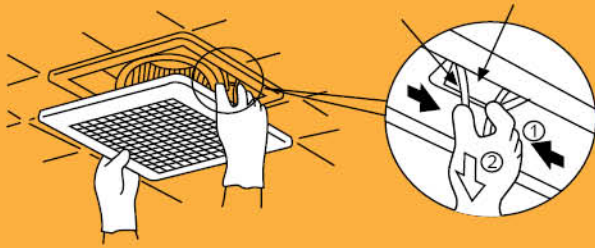

1. Remove louver.



2. Wash and clean louver.

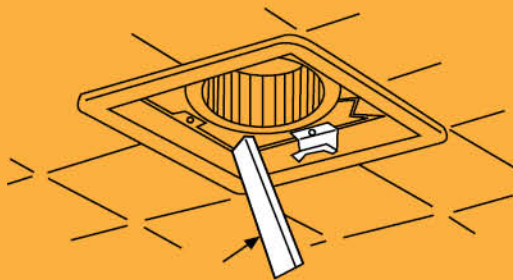

3. Remove dust and dirt on fan body by a cleaner.



4. Using a cloth dampened with kitchen detergent, remove any dirt from fan body. Wipe dry with new cloth. Replace louver.

Industrial Type Ventilating Fan can be used in factories, warehouses, shops, commercial kitchens and other places where large air change is necessary. Particular models are applicable for the places being ventilated by duct pipe through which static pressure is relative high.

### 1 High Static Pressure, Low Power Consumption

The newly developed fan and original bellmouth construction enable operation with high static pressure and low power consumption.

\* Fan with 3-dimensional S-shaped cross-section blade

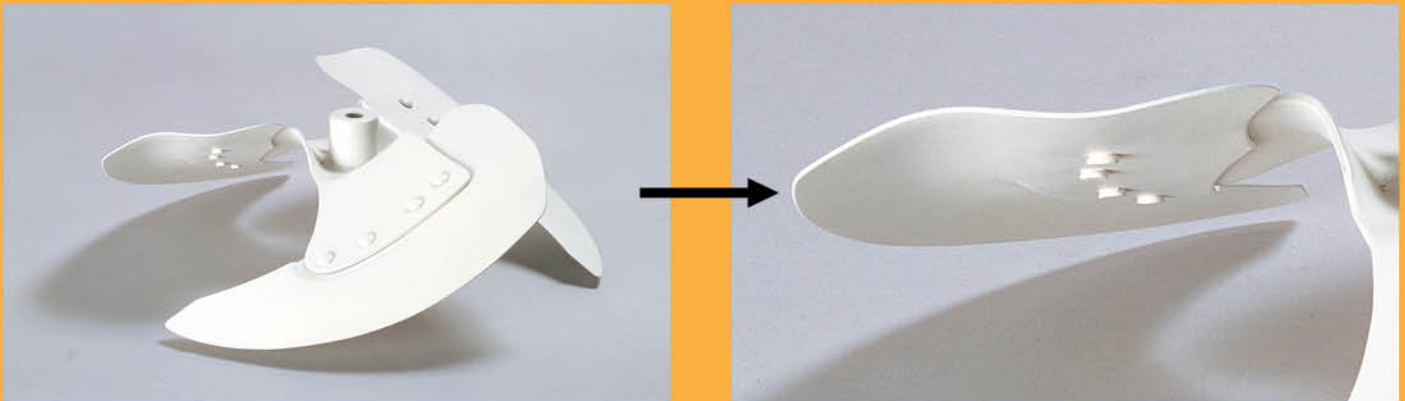

### 2 Low Noise Design

The fan blade's distinctive wave shape, developed using hydrodynamic analysis, delivers a smooth, turbulence-free airflow. The result is more air with less noise.

\* Surface velocity vector diagram

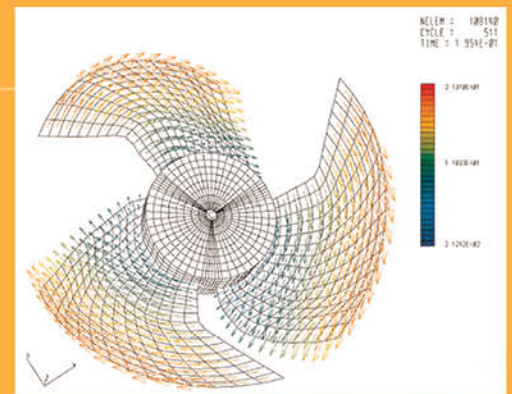

### 3 High Durability

Pressure is distributed more uniformly over the surface of the new fan blade, making the blade more durable. A special polyester resin and powder coating give a beautiful color and a highly rust-resistant finish. These ventilating fans can be used in factories, warehouses, shops, commercial kitchens, and other places where a big air change is necessary, as well as in places ventilated by using ducts where the static pressure is relative high.



FV-25GS4  
FV-30GS4  
FV-35GS4



FV-40GS4  
FV-45GS4  
FV-50GS4  
FV-60GS4  
FV-45GT4  
FV-50GT4  
FV-60GT4

- Bell mouth construction with distinctive wave shape blade
- Durable powder coating
- Unique drain mechanism
- High performance totally enclosed motor with thermal cut-off
- Able to be used over an ambient temperature range of from -10°C to +50°C
- Possible to install horizontally or vertically

Single-phase, Reversible		Three-phase, Reversible
FV-25GS4 (25cm/10")	FV-40GS4 (40cm/16")	FV-45GT4 (45cm/18")
FV-30GS4 (30cm/12")	FV-45GS4 (45cm/18")	FV-50GT4 (50cm/20")
FV-35GS4 (35cm/14")	FV-50GS4 (50cm/20")	FV-60GT4 (60cm/24")
	FV-60GS4 (60cm/24")	

## Specifications

Model	Phase	Rating Voltage	Air Volume		Power Consumption [W]	Fan Speed [R.P.M]	Noise [dB(A)]	Weight [Kg]
			[CMH]	[l/s]				
FV-25GS4	1	220~240V / 50Hz	1,150	319	39	1,360	34	4.4
FV-30GS4			1,820	505	59	1,360	38	6.1
FV-35GS4			2,560	711	88	1,420	44	10.5
FV-40GS4			3,610	1,002	161	1,450	47	19
FV-45GS4			5,200	1,444	227	1,410	51	19
FV-50GS4			6,130	1,702	249	960	47	22.5
FV-60GS4			8,040	2,233	245	970	50	34
FV-45GT4	3	380~440V / 50Hz	5,420	1,505	240	1,460	52	18.5
FV-50GT4			7,240	2,011	350	1,400	54	28.5
FV-60GT4			9,700	2,694	340	960	50	34

### Dimensions

- FV-25GS4
- FV-30GS4
- FV-35GS4

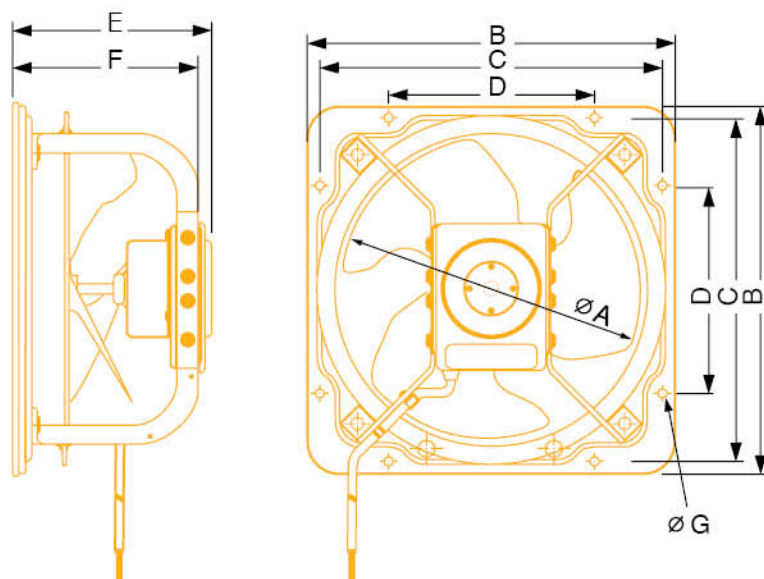

unit : mm

Model	A	B	C	D	E	F	G
FV-25GS4	250	327	298	165	171	164	10
FV-30GS4	300	378	349	210	200	187	10
FV-35GS4	350	467	434	250	236	219	12

- FV-40GS4
- FV-45GS4
- FV-50GS4
- FV-60GS4
- FV-45GT4
- FV-50GT4
- FV-60GT4

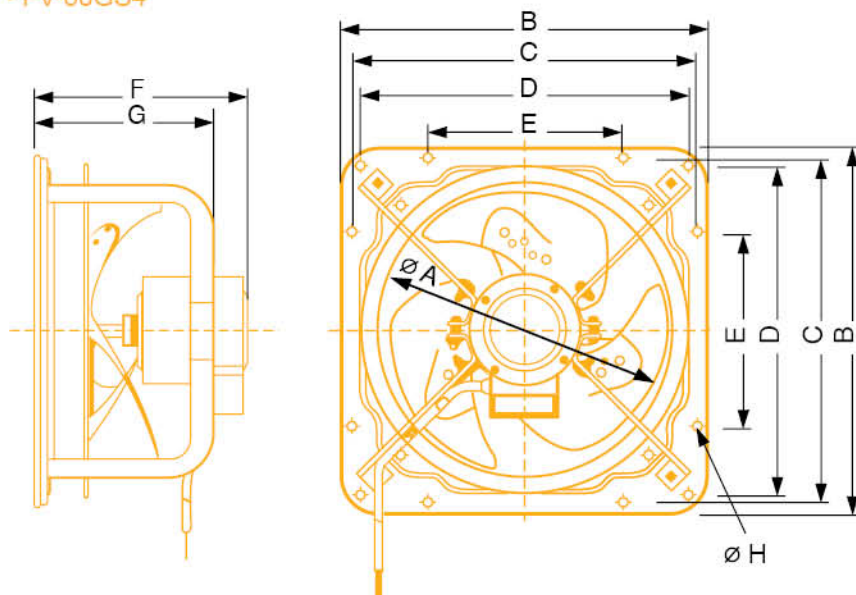

unit : mm

Model	A	B	C	D	E	F	G	H
FV-40GS4	400	518	485	460	280	274	225	12
FV-45GS4	450	570	540	-	320	297	248	12
FV-50GS4	500	659	620	560	355	315	266	15
FV-60GS4	600	760	720	650	400	320	262	15
FV-45GT4	450	570	540	-	320	297	248	12
FV-50GT4	500	659	620	560	355	304	246	15
FV-60GT4	620	760	720	650	400	320	262	15



Performance Data

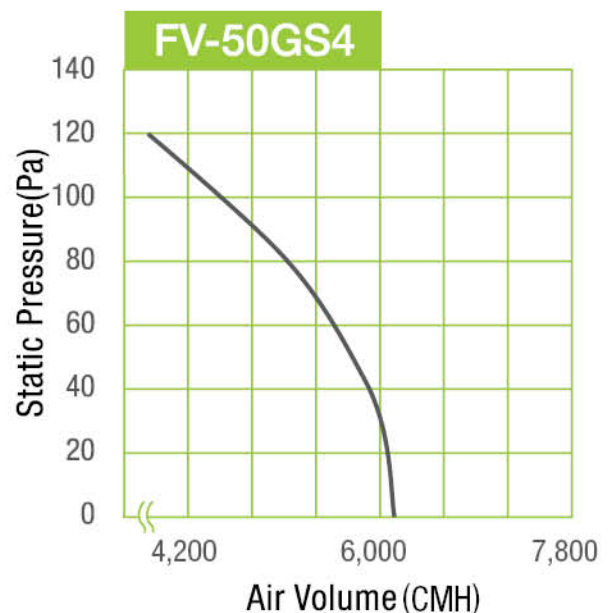
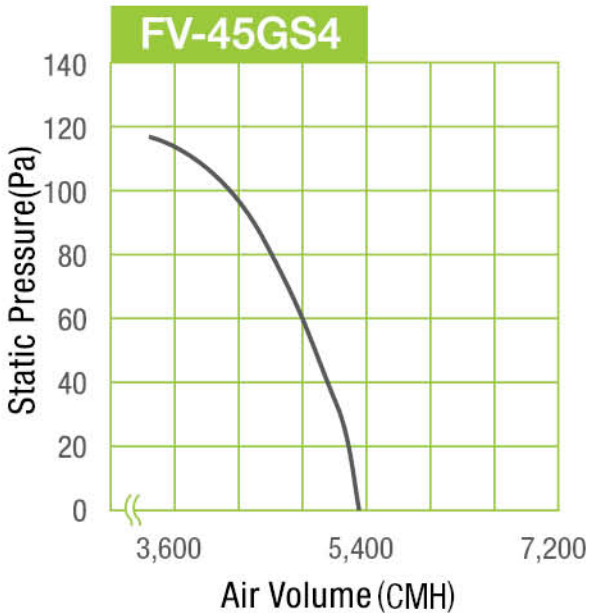
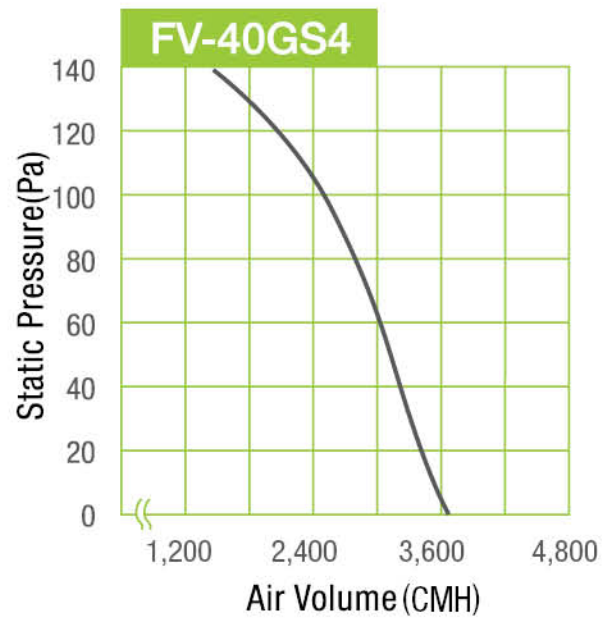
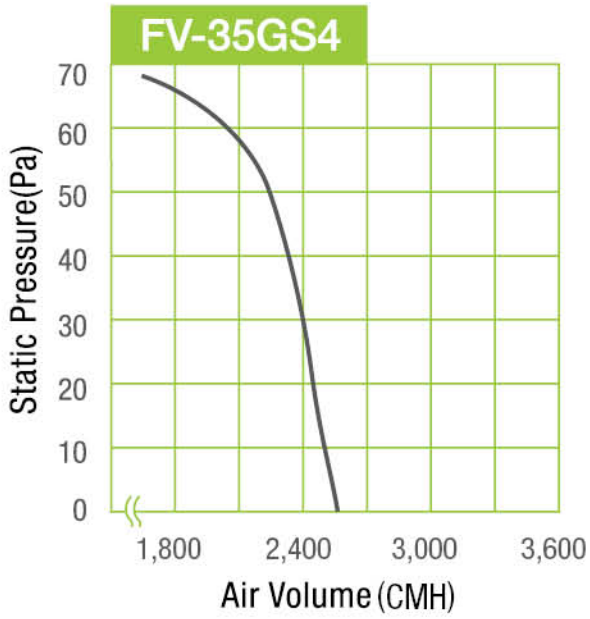
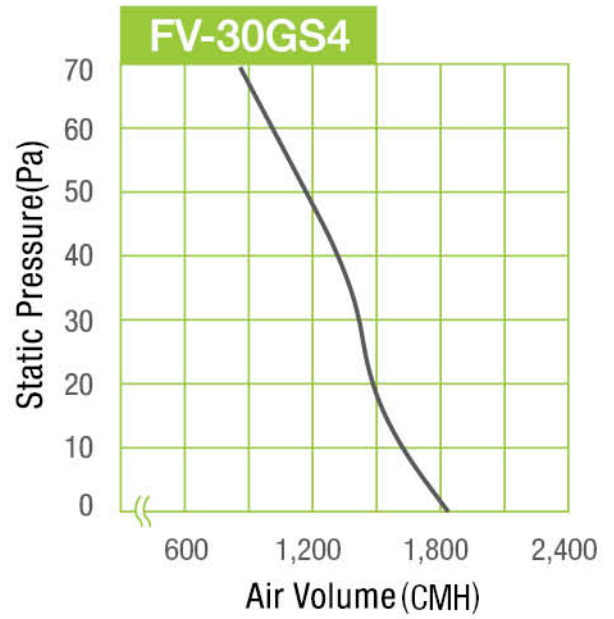
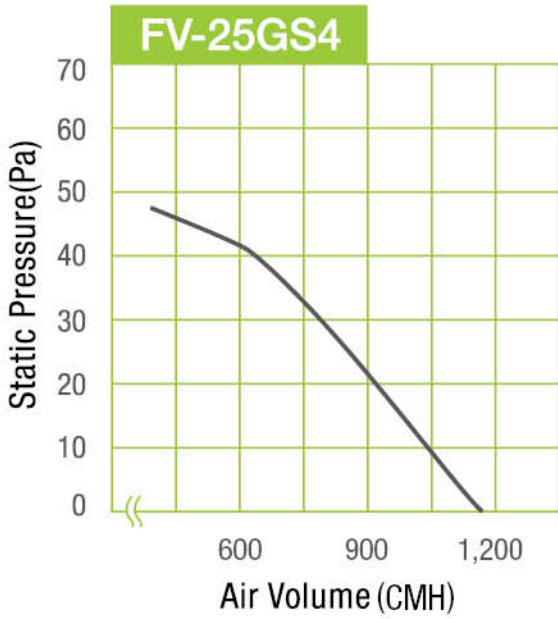

## Performance Data

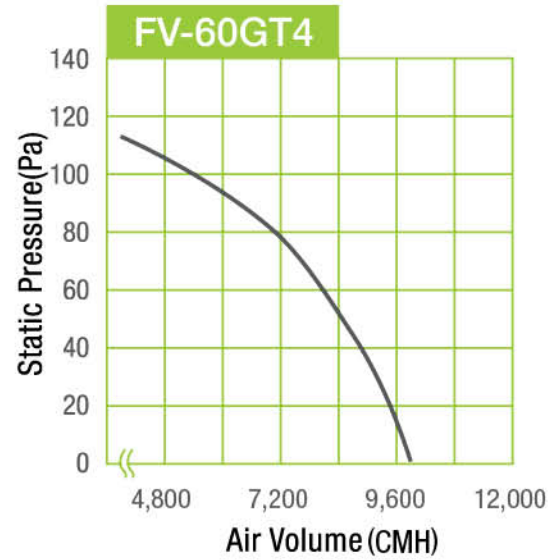
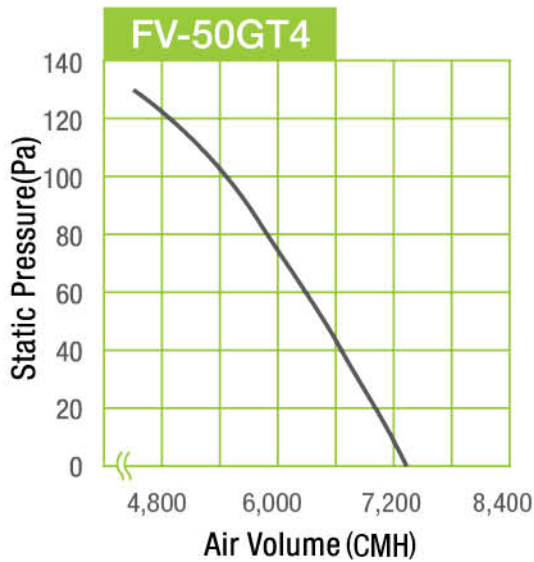
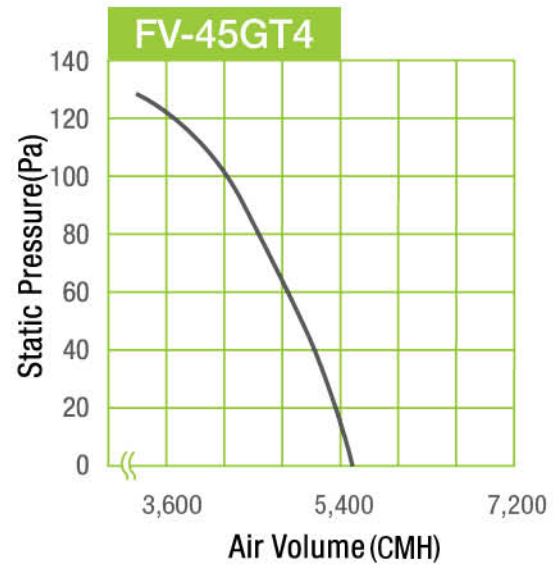
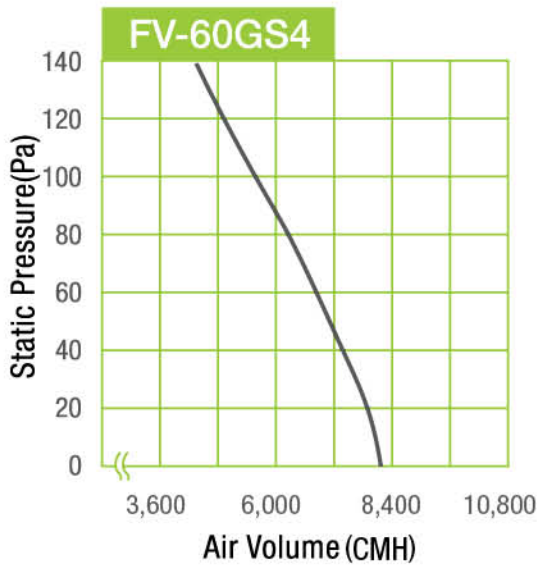

## Wiring Diagram

For single-phase models

- 1) Reverse the rotation in which the blade faces for reverse operation.
- 2) Please exchange the connections of the two terminals. (Red & Yellow)

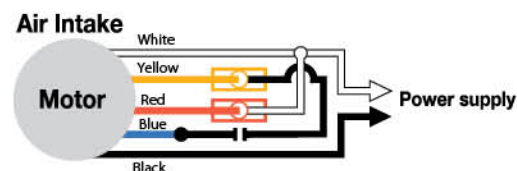
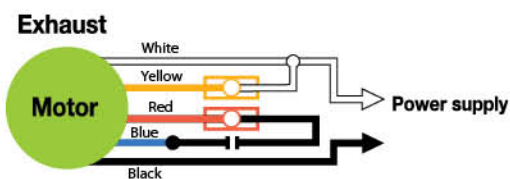

For three-phase models

- 1) Reverse the rotation in which the blade faces for reverse operation.
- 2) Please exchange the connections of any two wires.

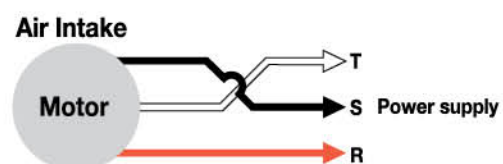
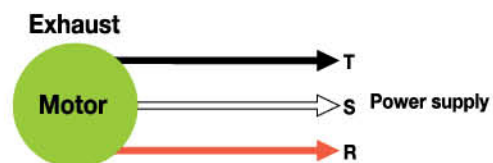



# AIR MOVING EQUIPMENT

Introduction

19

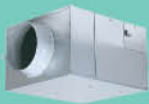

Low-noise Type Cabinet Fans (In-line Fans)

20



Plastic Type Cabinet Fans

24



Mini Sirocco Fans

26



Recessed Light Fan

30



Centrifugal Fans

32



Adjustable Pitch Axial Flow Fans

36

Low Noise Type Cabinet Fans are ducted ventilating fans with both intake and outlet opening fixing at interior and exterior of the house respectively. They can be used as single port or multi port to exhaust air from several areas with one unit. Since only a small ventilation opening is required, the appearance of the interior is not spoiled.

All models are manufactured from galvanized steel enhancing high durability. The unique suction fan design and acoustic noise absorbing material realize low noise operation. The high performance induction motor offers low consumption, long life and high reliability.

The slim, compact and light-weight structure allows easy installation at narrow ceiling space. Those units can be installed upside down, that location of inspection opening can be selected to ensure easy access for maintenance. Particular U-grooved mounting brackets prevent loosen of mounting bolts that reinforce installation safety.

Two speed selection enhances the scope of application and increases the flexibility for planning of ventilation system (except FV-28NX3H). Moreover, single or three phase model are available for different requirement.

Remark: The ventilation fans are considered suitable for use in ventilation system. In case the fan is to be installed in a protected area, the designer shall ensure that the equipment is in compliance with the relevant requirements and safety standards stipulated in Section 5.2.3 Part XI of FSD Circular 4/96.

### Compact Size

- Slim and compact design allows easy installation at narrow ceiling space

### High Air Volume Airflow

- Powerful airflow velocity creates a better performance

### Twin Flow Fan

- It divides into two portions which can generate large air volume and high static pressure
- Achieves a better airflow inside the fan casing

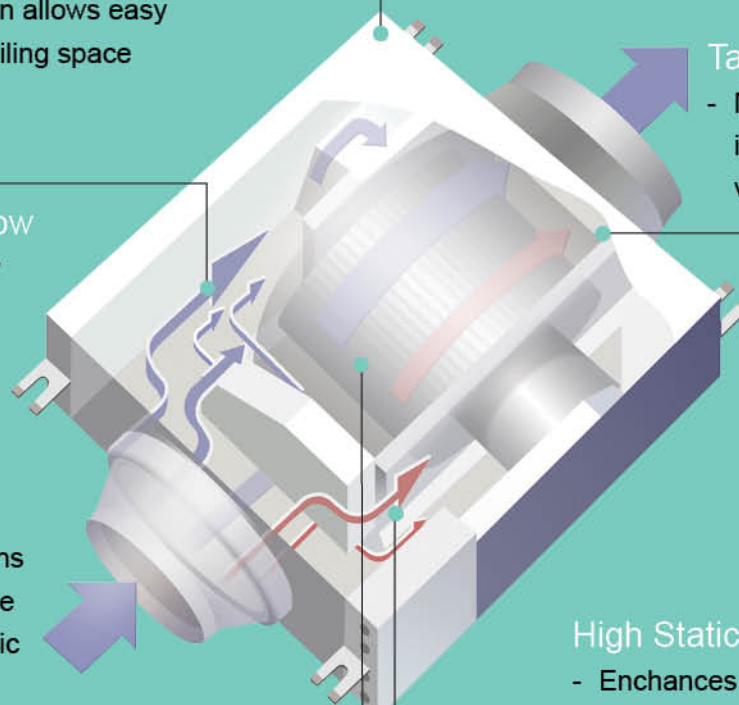

### Tapered Scroll

- Minimizes the turbulence induced by uneven wind velocity inside the casing

### High Static Pressure Airflow

- Enhances the flexibility for planning of a ventilation system



Single Phase



Three Phase

- Long life condenser motor with thermal cut-off
- Twin flow fan (sirocco fan)
- Fan casing with tapered scroll
- Embedded terminal box
- Noise absorption material
- Compact size
- Being acceptable by Hong Kong Fire Service Department (FSD)

\* Relevant requirement for installed area should be fulfilled.

Single Phase			Three Phase
FV-12NS3H	FV-15NS3H	FV-18NS3H	FV-28NX3H
FV-18NF3H	FV-20NS3H	FV-23NL3H	
FV-25NS3H	FV-25NF3H		

## Specifications

Model	RatingVoltage	Air Volume		Power Consumption [W]	Fan Speed [R.P.M]	Noise [dB(A)]	Weight [Kg]	Impeller Diameter [mm]	Number of Poles
		[CMH]	[l/s]						
FV-12NS3H	Hi	180	50	18	1,265	21	5.5	128	4
	Lo	145	40	17	1,020	17			
FV-15NS3H	Hi	340	94	33	1,270	25	6.5	128	
	Lo	275	76	29.5	1,100	22			
FV-18NS3H	Hi	500	139	60	1,250	29	8.5	158	
	Lo	405	112	55	1,100	27			
FV-18NF3H	Hi	770	214	91	1,190	31	10	158	
	Lo	620	172	80	1,000	29			
FV-20NS3H	Hi	920	255	120	1,195	32	14	178	
	Lo	720	200	113	1,000	29			
FV-23NL3H	Hi	1,200	333	230	1,245	40	18	220	
	Lo	900	250	170	985	34			
FV-25NS3H	Hi	1,700	472	345	1,125	41	24	220	
	Lo	1,380	383	265	950	38			
FV-25NF3H	Hi	1,900	528	390	1,225	43	24	220	
	Lo	1,600	444	325	1,070	40			
FV-28NX3H	380V / 50Hz	2,600	722	600	1,295	44	28	280	-

### Notes :

1. The values of rated input, air volume and noise are specified at the static pressure of 0 Pa.
2. The values of noise level is A weighted average sound pressure level, the mean value are measured by our company, within +3 and -7 tolerance.
3. The values of noise level are measured at the 1.5m apart from the side of the fan body when ducts are connected on both inlet and outlet side. It is on the assumption that the noise of fan body propagates to room inside.
4. The values of air volume are the mid-points of results measured by our company, with ±10% tolerance.

### Cautions :

- Don't use it for ventilation at a site generating heat, oily smoke, steam and/or moisture. (Environment condition: -10°C ~ +40°C, relative humidity below 85%)
- Install a door 600x600mm or more for maintenance purpose.
- Install a leak breaker or a motor breaker on the source site. A control panel such as a contact switch relay is required for three phase power source.
- In cold air supply to indoor during winter and at any other occasion susceptible to dew drop, heat insulation is required.
- It is recommended to use a commercially available filter at the suction side to avoid dust and/or oil waste attachment on a blade.
- Install it on a horizontal direction.
- Do not perform parallel operation of more than one unit on a switch, for it may result in motor failure.

### Dimensions

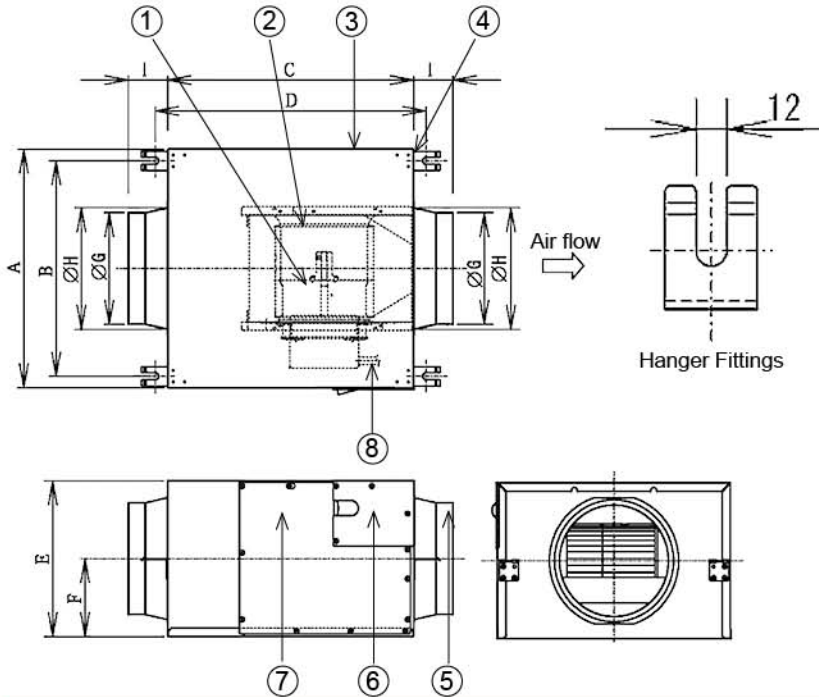

#### Parts List

No.	Part name	Qty	Material
1	Impeller	1	Metal
2	Motor	1	-
3	Fan casing	1	Metal
4	Hanger fitting	4	Metal
5	Adaptor	2	Metal
6	Terminal cover	1	Metal
7	Inspection panel	1	Metal
8	Metal conduit	1	Metal

unit : mm

Model	A	B	C	D	E	F	G	H	I	Duct size
FV-12NS3H	290	250	291	335	184	92	97	112	51	Ø100
FV-15NS3H	290	250	302	346	206	103	145	163	60	Ø150
FV-18NS3H	316	276	338	382	232	116	145	163	60	Ø150
FV-18NF3H	376	336	397	441	254	127	195	211	70	Ø200
FV-20NS3H	416	376	441	485	272	136	195	211	70	Ø200
FV-23NL3H	468	424	469	513	298	149	195	211	70	Ø200
FV-25NS3H	494	450	505	549	334	167	240	255	85	Ø250
FV-25NF3H	494	450	505	549	334	167	240	255	85	Ø250

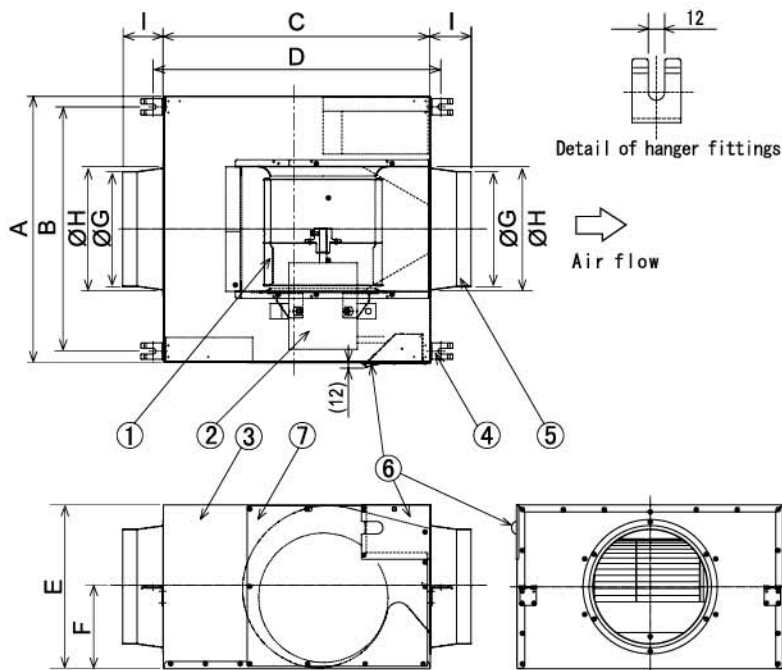

#### Parts List

No.	Part name	Qty	Material
1	Impeller	1	Metal
2	Motor	1	-
3	Frame	1	Metal
4	Adapter	2	Metal
5	Terminal cover	1	Metal
6	Inspecting panel	1	Metal
7	Metal conduit	1	Metal

unit : mm

Model	A	B	C	D	E	F	G	H	I	Duct size
FV-28NX3H	554	510	557	601	342	171	240	255	85	Ø250

Performance Data

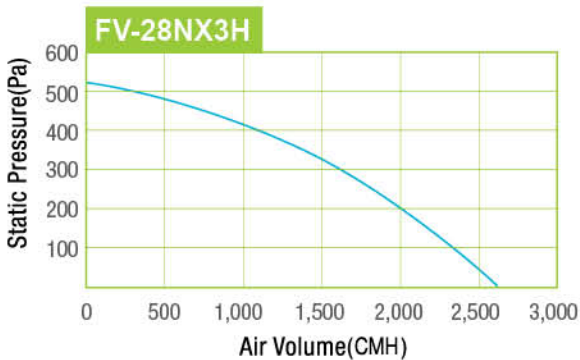
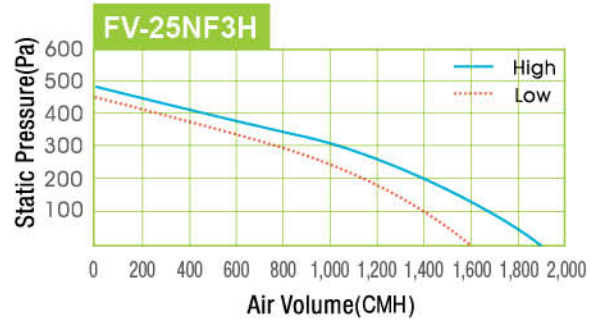
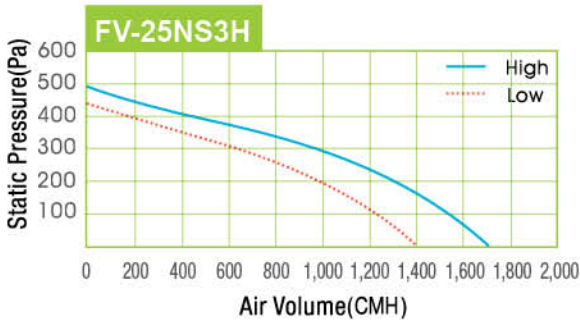
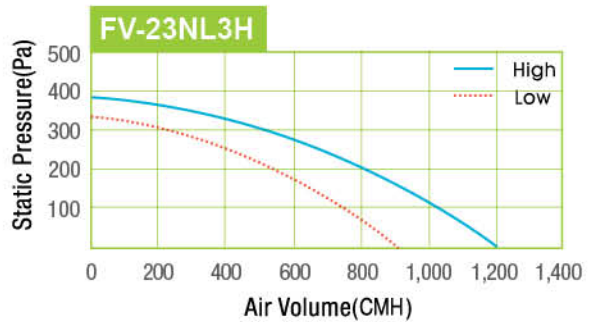
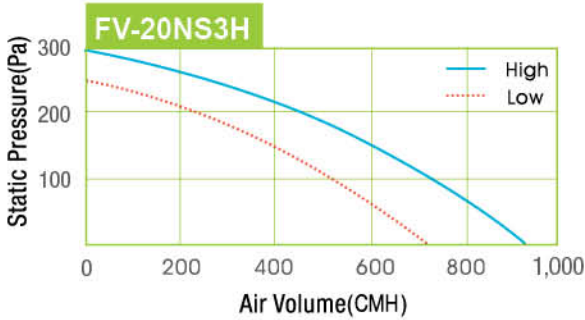
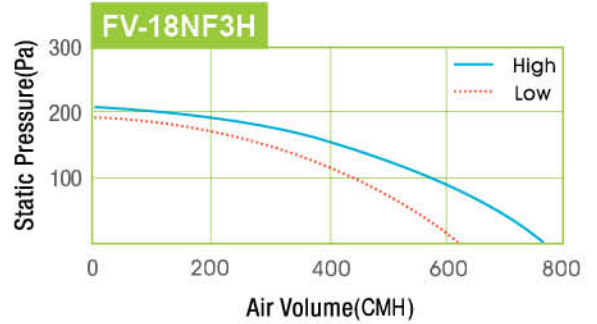
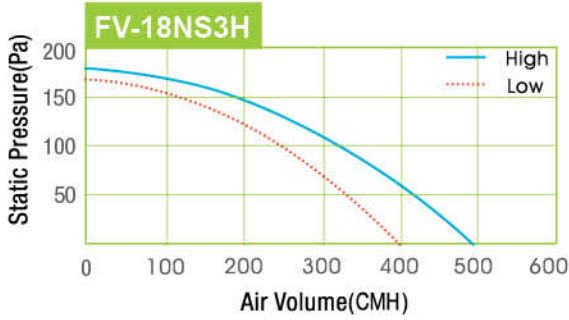
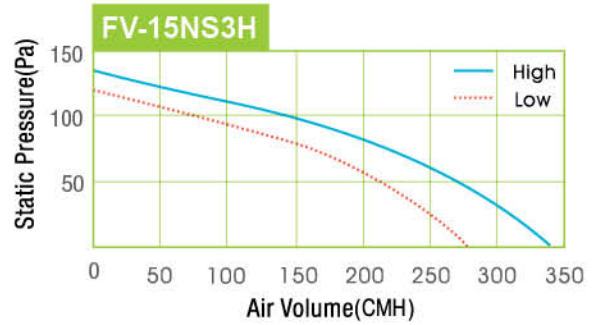
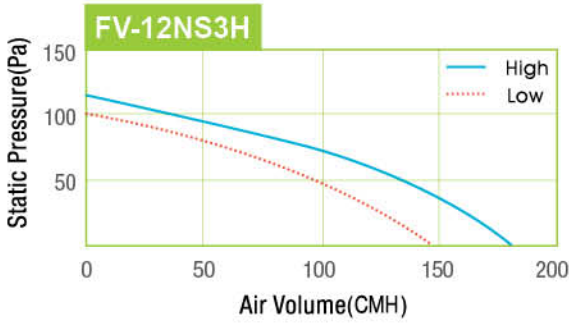

### Wiring Diagram

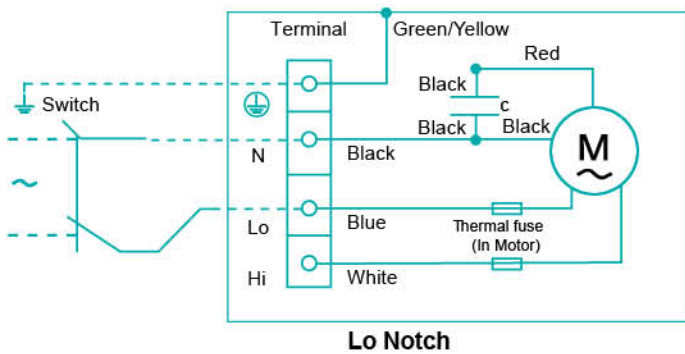
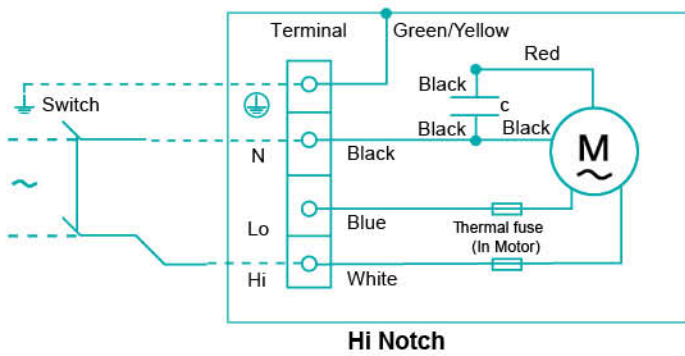

- FV-12NS3H
- FV-15NS3H
- FV-18NS3H
- FV-18NF3H
- FV-20NS3H
- FV-23NL3H
- FV-25NS3H
- FV-25NF3H

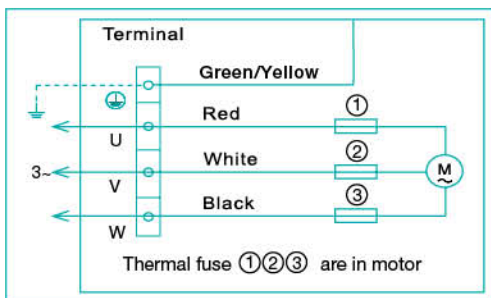

- FV-28NX3H

### Test Standard

Noise characteristic is measured according to our internal standard as shown.

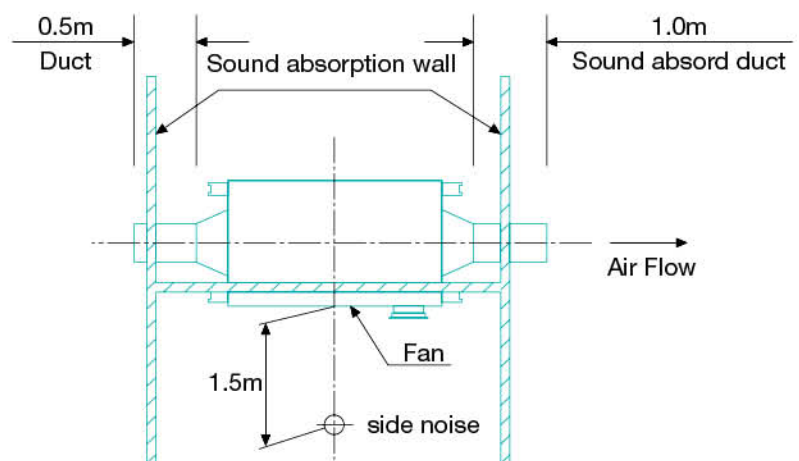

\*The values of noise level are measured at the 1.5m apart from the side of the fan body when dusts are connected on both inlet and outlet side. It is on the assumption that the noise of fan body propagates to room inside.





- Slim design
- Compact size, 33% less than steel type cabinet fan
- Long life motor with thermo cut-off
- Special design blade achieving high static pressure

Single Phase	
FV-02NU1H	FV-05NU1H
FV-04NU1H	FV-07NU1H

### Performance Data

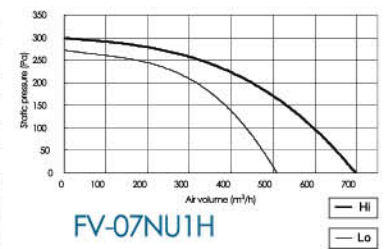
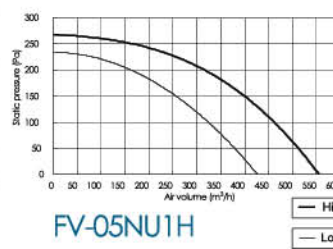
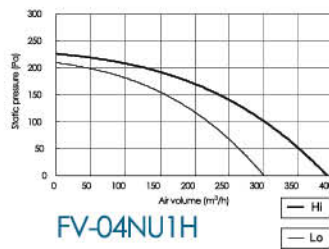
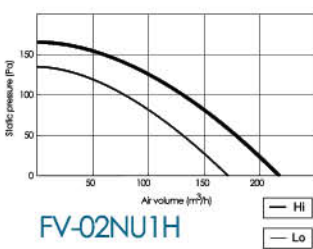

### Specifications

Model	Rating Voltage	Air Volume		Power Consumption [W]	Fan Speed [R.P.M]	Noise level [dB(A)]	Weight [Kg]	Impeller Diameter [mm]	No. of Poles	
		[CMH]	[l/s]							
FV-02NU1H	220V / 50Hz	Hi	218	61	27	890	24	3.8	200	4
		Lo	170	47	24	710	21			
FV-04NU1H	220V / 50Hz	Hi	392	109	62	1,065	31	4.4	200	
		Lo	300	83	48	850	25			
FV-05NU1H	220V / 50Hz	Hi	554	154	83	980	34	6.4	230	
		Lo	425	118	70	760	28			
FV-07NU1H	220V / 50Hz	Hi	694	193	118	1,240	37	8.3	230	
		Lo	510	142	108	900	31			

#### Notes :

1. The values of rated input, air volume and noise are specified at the static pressure of 0 Pa.
2. The values of noise level is A weighted average sound pressure level, the mean value are measured by our company, within +3 and -7 tolerance.
3. The values of noise level are measured at the 1.5m apart from the inspection panel of the fan body when ducts are connected on both inlet and outlet side. It is on the assumption that the noise of fan body propagates to room inside.
4. The values of air volume are the mid-points of results measured by our company, with ±10% tolerance.

#### Cautions :

- Don't use it for ventilation at a site generating heat, oily smoke, steam and/ or moisture. (Environment condition: -10°C ~ +40°C, relative humidity below 85%)
- Install a door 600x600mm or more for maintenance purpose.
- Install a leak breaker or a motor breaker on the source site.
- In cold air supply to indoor during winter and at any other occasion susceptible to dew drop, heat insulation is required.
- It is recommended to use a commercially available filter at the suction side to avoid dust and/or oil waste attachment on a blade.
- Install it on a horizontal direction.
- Do not perform parallel operation of more than one unit on a switch, for it may result in motor failure.

### Dimensions

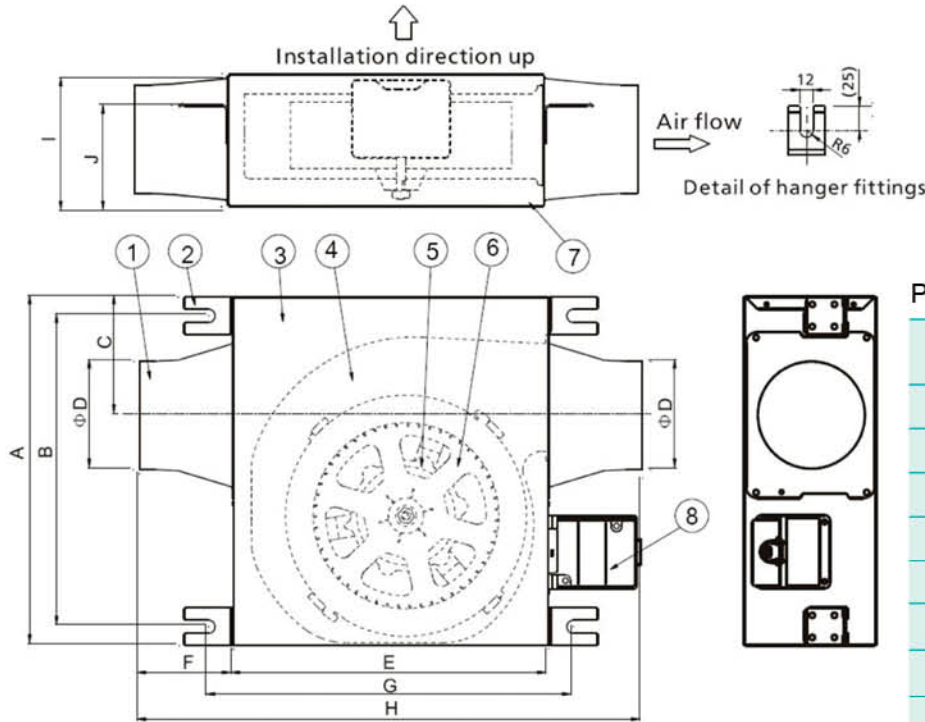

#### Parts List

No.	Part name	Qty	Material
1	Adapter	2	Metal
2	Hanger fittings	4	Metal
3	Inspection panel	1	Metal
4	Casing assy.	1	Plastic
5	Motor	1	-
6	Blade	1	Plastic
7	Fan casing	1	Metal
8	Wiring box cover	1	Plastic

unit : mm

Model	A	B	C	D	E	F	G	H	I	J	Duct size
FV-02NU1H	315	281	107	98	285	85	330	455	120	92	Ø100
FV-04NU1H	315	281	118	148	285	100	330	485	170	107	Ø150
FV-05NU1H	362	327	119	148	338	100	383	538	170	107	Ø150
FV-07NU1H	362	327	119	148	338	100	383	538	170	107	Ø150

### Wiring Diagram

#### High Notch

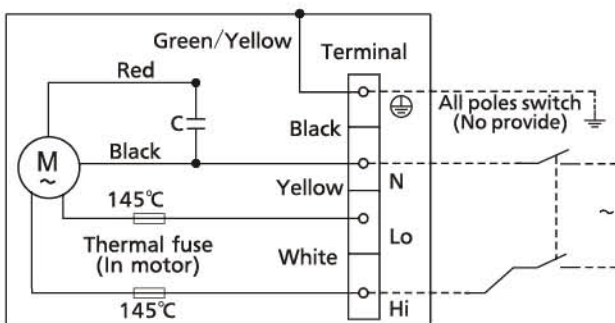

#### Low Notch

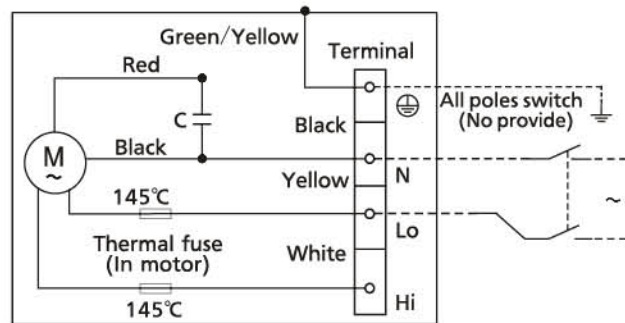



- Act as ventilation system
- Long life induction motor with thermo cut-off
- Single Speed
- Outlet direction is adjustable to vertical or horizontal position
- Able to be used over an ambient temperature range from -10°C to +40°C

### Single Phase

FV-10CG1H	FV-17CG1H
FV-14CG1H	FV-19CG1H
FV-16CG1H	FV-21CG1H

## Specifications

Model	Rating Voltage	Air Volume		Power Consumption [W]	Fan Speed [R.P.M]	Noise level [dB(A)]	Weight [Kg]	Impeller Diameter [mm]	No. of Poles	
		[CMH]	[l/s]							
FV-10CG1H	220V / 50Hz	150	42	15.5	1,094	34.5	2.5	120	4	
FV-14CG1H		300	83	33	970	41	3.6	120		
FV-16CG1H		500	139	47	1,030	49.5	5.2	150		
FV-17CG1H		Hi	770	214	85	870	47	9.3		180
		Lo	660	183	73.5	743	43			
FV-19CG1H		950	264	120	1,083	52.5	9.3	180		
FV-21CG1H		Hi	1,550	430	224	1,335	60	18		200
		Lo	1,200	333	182	1,120	55			

#### Notes :

1. The values of rated input, air volume and noise are specified at the static pressure of 0 Pa.
2. The values of noise level is A weighted average sound pressure level, the mean value are measured by our company, within +3 and -7 tolerance.
3. The values of noise level are measured at the 1.5m apart from the side of the fan body when ducts are connected on both inlet and outlet side. It is on the assumption that the noise of fan body propagates to room inside.
4. The values of air volume are the mid-points of results measured by our company, with ±10% tolerance.

#### Cautions :

- Don't use it for ventilation at a site generating heat, oily smoke, steam and/ or moisture. (Environment condition: -10°C ~ +40°C, relative humidity below 85%)
- Install a door 600x600mm or more for maintenance purpose.
- Install a leak breaker or a motor breaker on the source site.
- In cold air supply to indoor during winter and at any other occasion susceptible to dew drop, heat insulation is required.
- It is recommended to use a commercially available filter at the suction side to avoid dust and/or oil waste attachment on a blade.
- Install it on a horizontal direction.
- Do not perform parallel operation of more than one unit on a switch, for it may result in motor failure.

### Dimensions

No.	Part name	Qty
1	Fan casing	1
2	Motor	1
3	Impeller	1
4	Motor support	4
5	Terminal cover	2
6	Inlet flange	1
7	Outlet flange	1

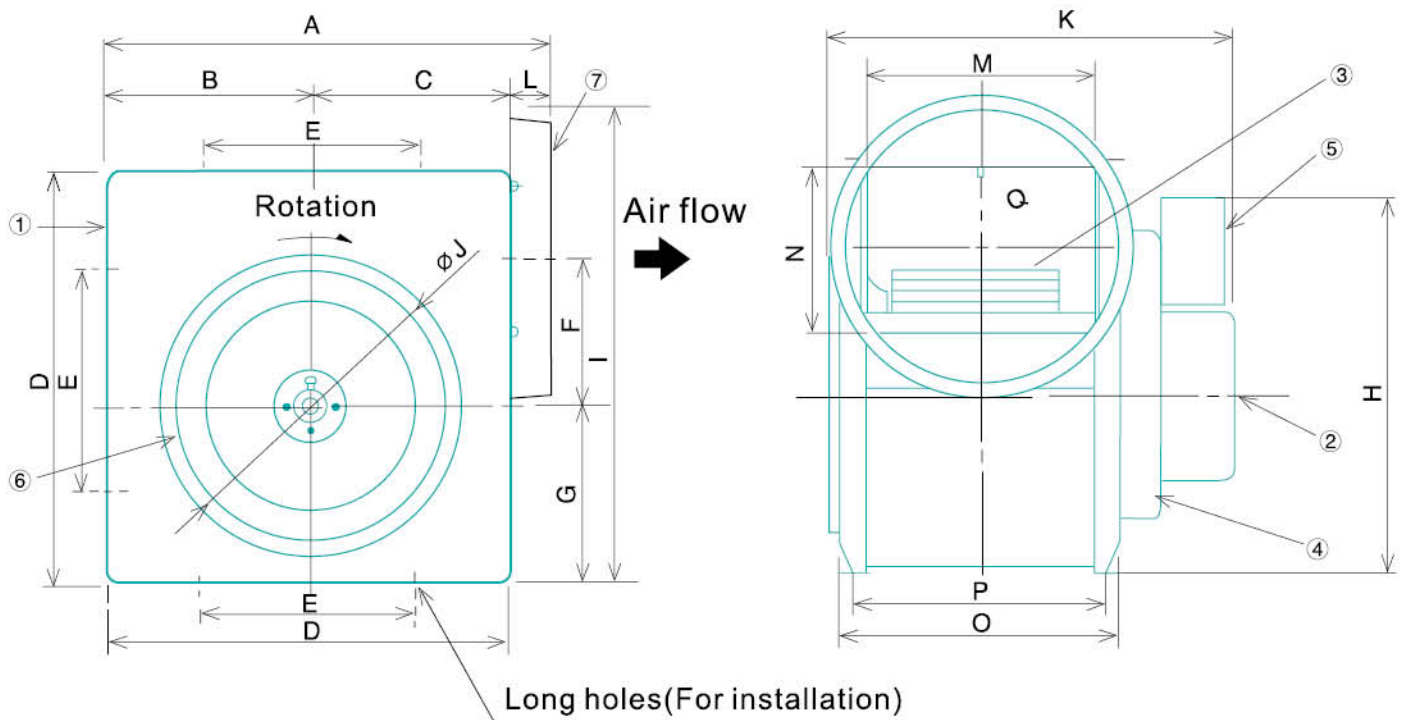

unit : mm

Model	A	B	C	D	E	F	G	H	I	J	K	L	M	N	O	P	Q	Connector Duct
FV-10CG1H	206	86	95	180	120	56	82	208	199	98	212	24	80	73	120	106	98	Ø100
FV-14CG1H	261	112	119	230	120	76	95	224	256	148	242	29	105	98	145	131	148	Ø150
FV-16CG1H	281	125	126	250	160	87	108	250	281	148	255	29	117	102	157	143	148	Ø150
FV-17CG1H	331	151	150	300	160	106	130	291	346	198	307	29	165	115	205	187	198	Ø200
FV-19CG1H	331	151	150	300	160	106	130	291	346	198	307	29	165	115	205	187	198	Ø200
FV-21CG1H	361	166	165	330	200	121	145	233	377	198	375	29	190	110	250	226	198	Ø200

Performance Data

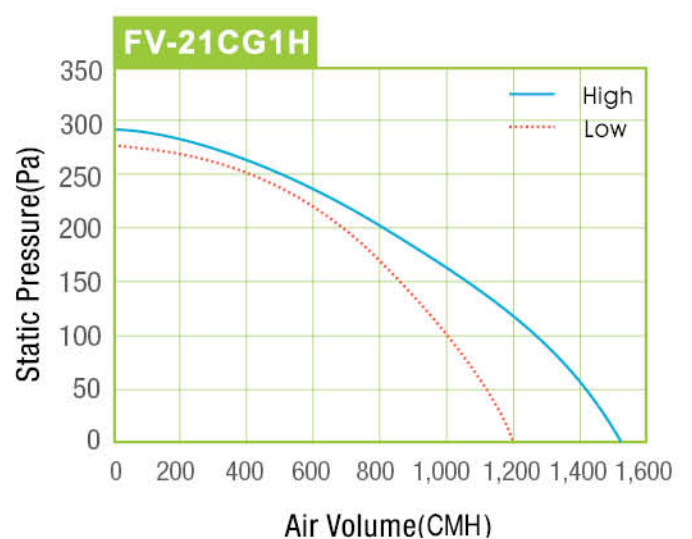
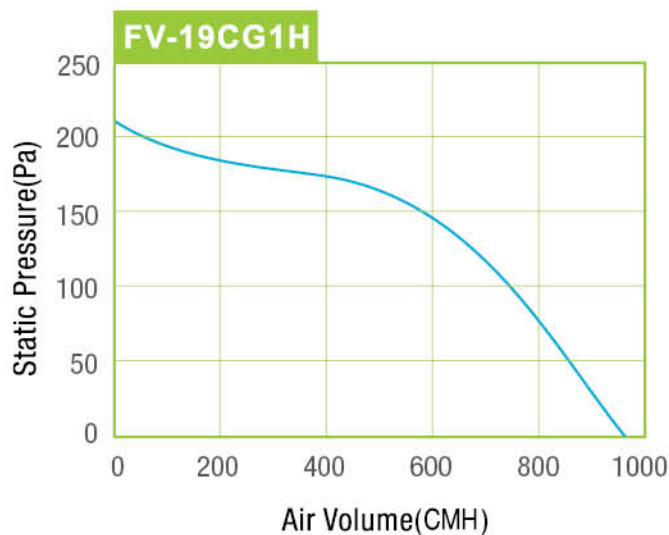
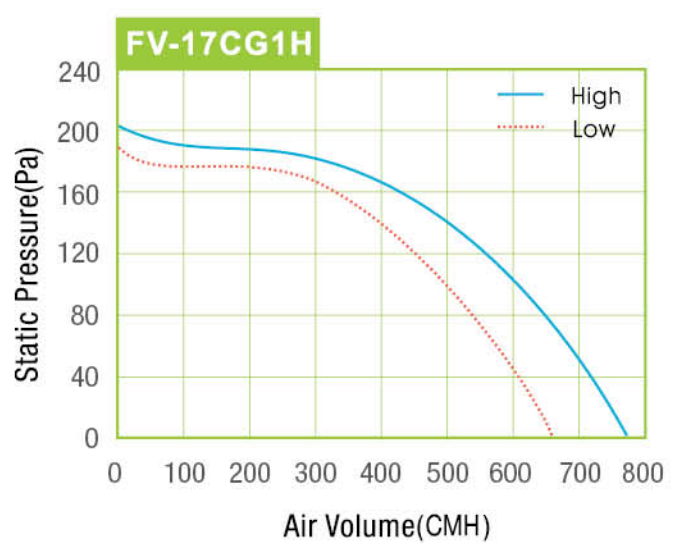
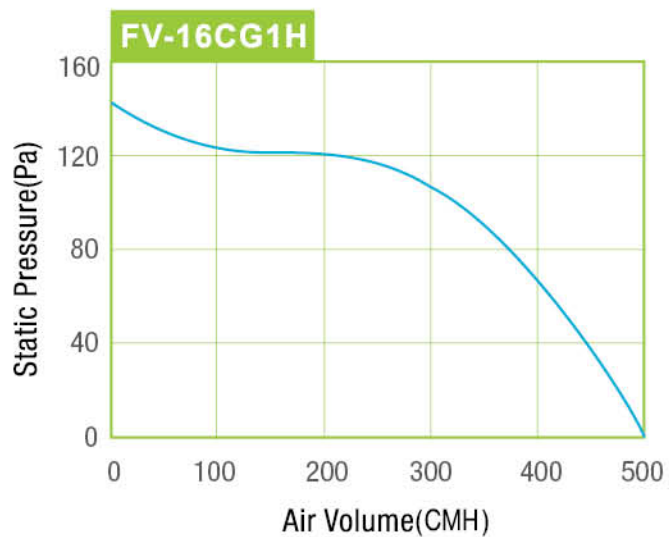
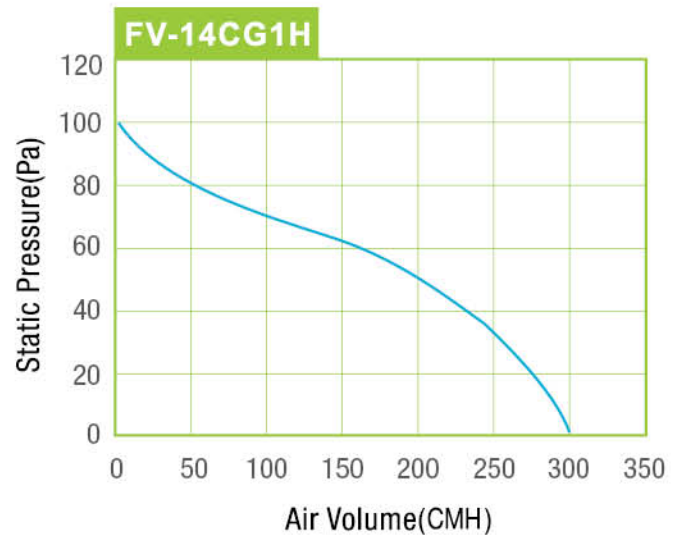
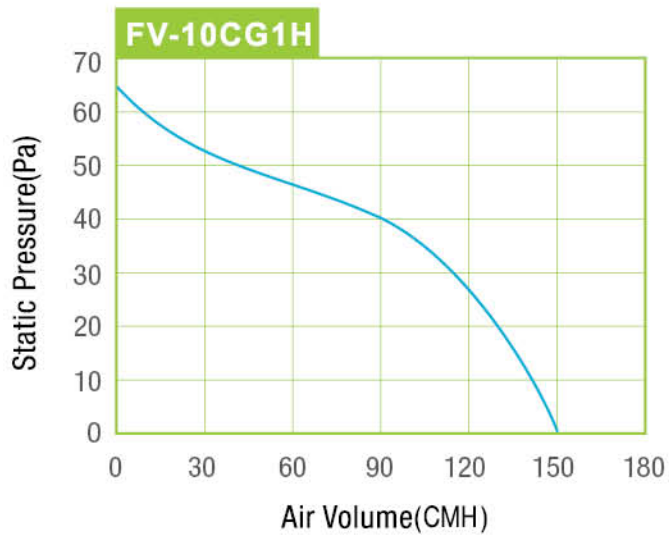

### Wiring Diagram

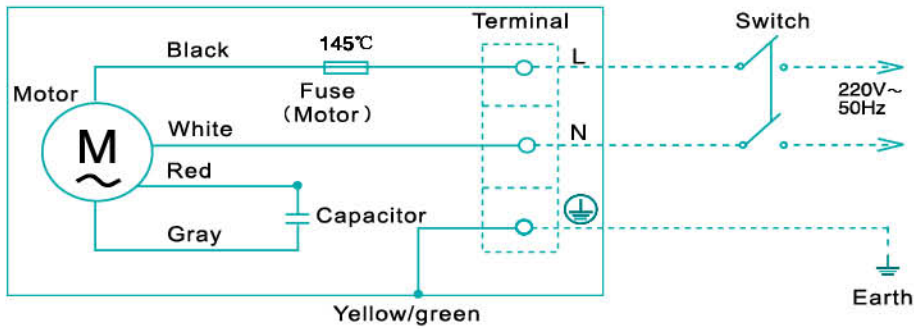

- FV-10CG1H
- FV-14CG1H
- FV-16CG1H
- FV-19CG1H

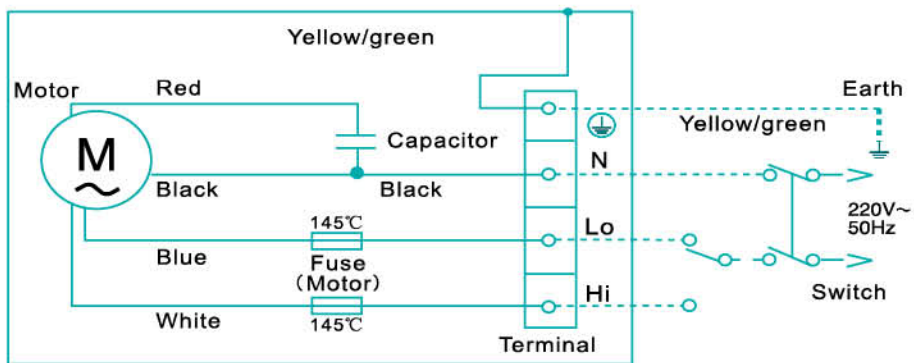

- FV-17CG1H

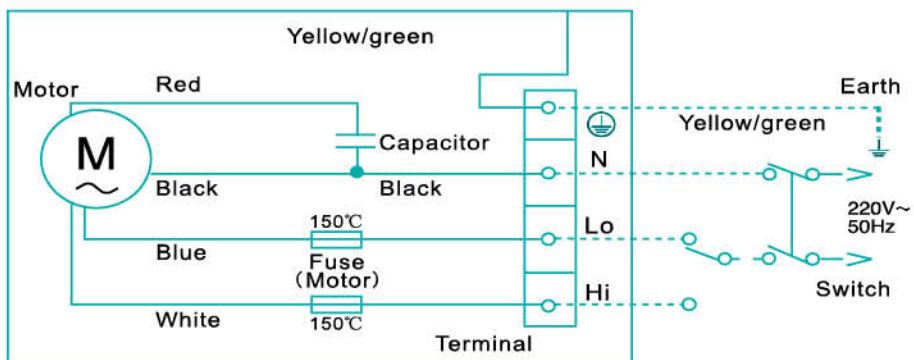

- FV-21CG1H

### Test Standard

Noise characteristic is measured according to our internal standard as shown.

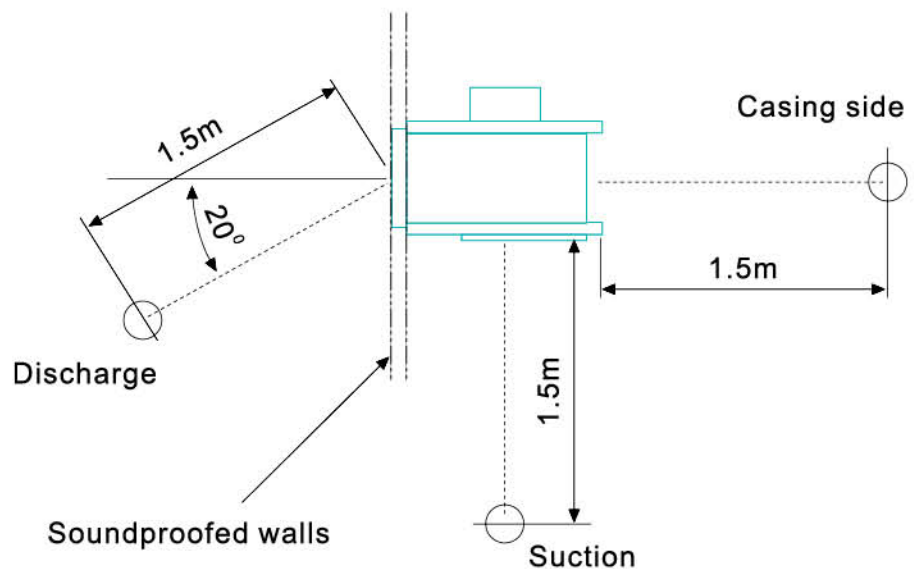



FV-15CL1

## Recessed Light Fan

- 2 in 1 - Ventilating Fan equipped with Light
- Long life motor with thermo cut-off
- 100 mm or 150 mm duct diameter applicable
- 2 speed selectable
- Max 23W Fluorescent lamp or LED lamp applicable

### Performance Data

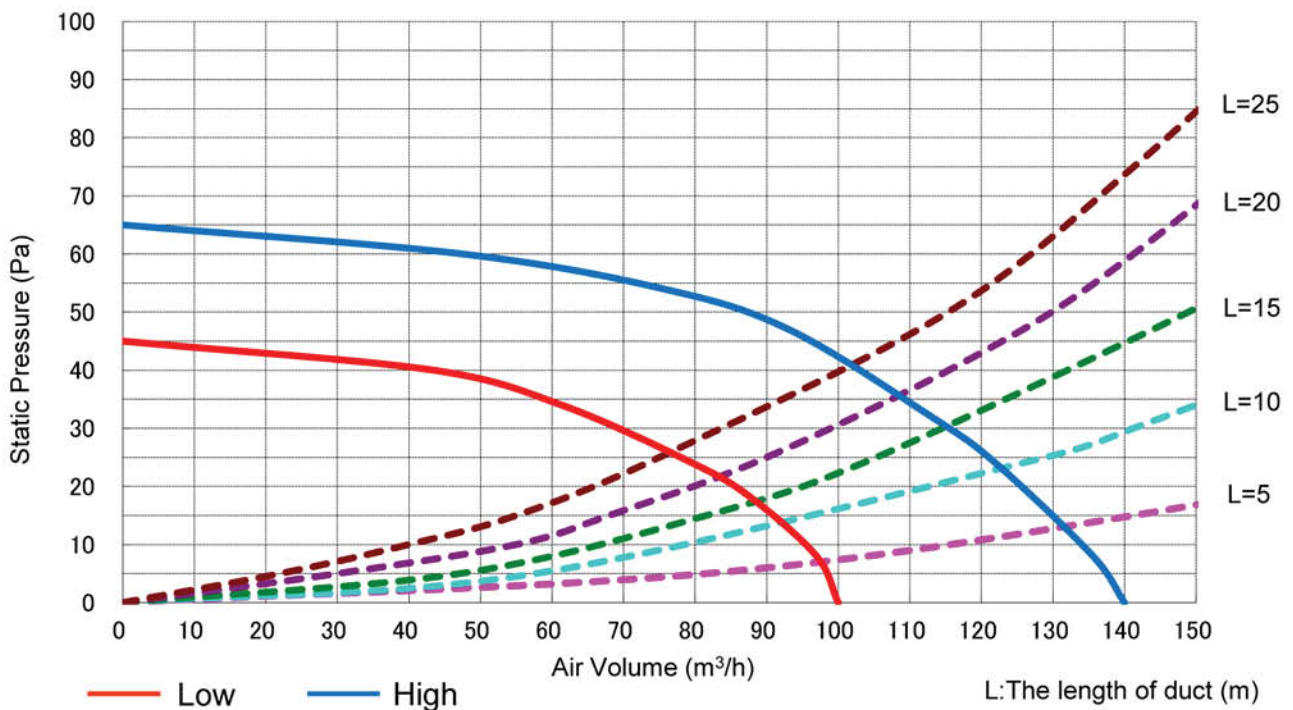

### Wiring Diagram

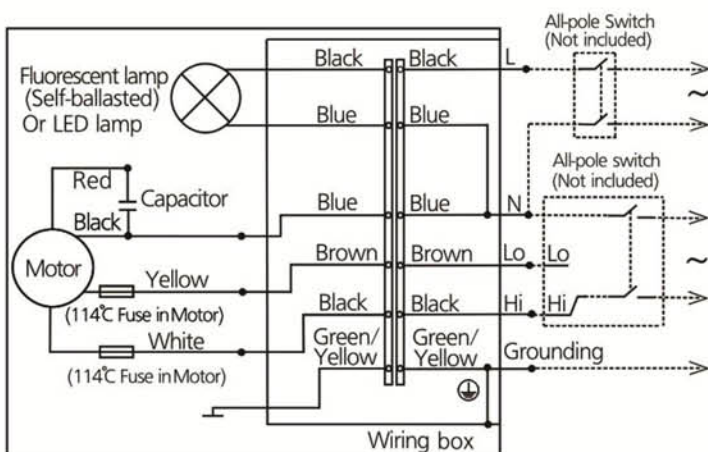

### Dimensions

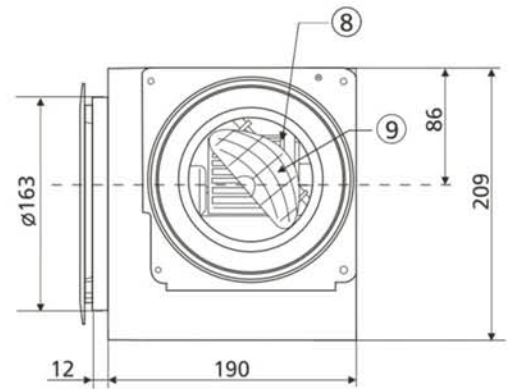
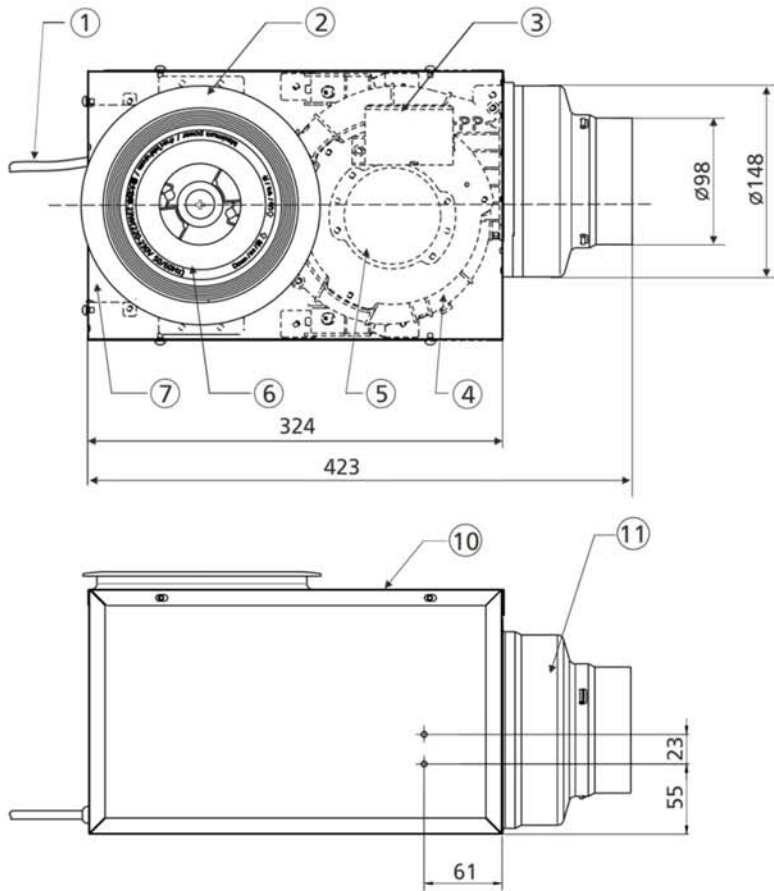

### Parts List

No.	Part name	Qty	Material
1	Power cord	1	0.75 mm <sup>2</sup> x 5
2	Trim	1	Plastic
3	Capacitor box	2	Plastic
4	Casing	1	Plastic
5	AC motor	1	-
6	Light unit assy.	1	PBT
7	Wiring box	1	Galvanized Steel
8	Fan	1	Plastic
9	Shutter	1	Plastic
10	Frame assy.	1	Galvanized Steel
11	Adapter	1	Galvanized Steel

### Specifications

Model	Rating Voltage	Air Volume		Power Consumption [W]	Fan Speed [R.P.M]	Noise [dB(A)]	Weight [Kg]	Impeller Diameter [mm]	Number of Poles	
		[CMH]	[l/s]							
FV-15CL1	Hi	220V / 50Hz	140	39	18	1,206	40	3.7	128	4
	Lo		100	28	13	865	33			

#### Notes :

- The values of rated input, air volume and noise are specified at the static pressure of 0 Pa.
- The values of noise level is A weighted average sound pressure level, the mean value are measured by our company, within +3 and -7 tolerance.
- The values of noise level are measured at 1m away from the left side / right side / bottom of the sample respectively, and then calculate the average value.
- The values of air volume are the mid-points of results measured by our company, with ±10% tolerance.
- The product is complied with IEC 60335-1 & IEC 60335-2-80.
- Not supplies fluorescent lamp or LED lamp.

#### Cautions :

- Don't use it for ventilation at a site generating heat, oily smoke, steam and/ or moisture. (Environment condition: -10°C ~ +40°C, relative humidity below 85%)
- Install a inspection hole 450x450mm or more for maintenance purpose.
- Install a leak breaker or a motor breaker on the source site.
- In cold air supply to indoor during winter and at any other occasion susceptible to dew drop, heat insulation is required.
- It is recommended to use a commercially available filter at the suction side to avoid dust and/or oil waste attachment on a blade.
- Install it on a horizontal direction.
- Do not perform parallel operation of more than one unit on a switch, for it may result in motor failure.





## Forward Curved Multi-Blade Fan SWSI

Three Phase		
FY-06FCS-C	FY-15FCS-C	FY-27FCS-C
FY-08FCS-C	FY-18FCS-C	FY-30FCS-C
FY-09FCS-C	FY-21FCS-C	FY-33FCS-C
FY-12FCS-C	FY-24FCS-C	FY-36FCS-C

### Selection Chart

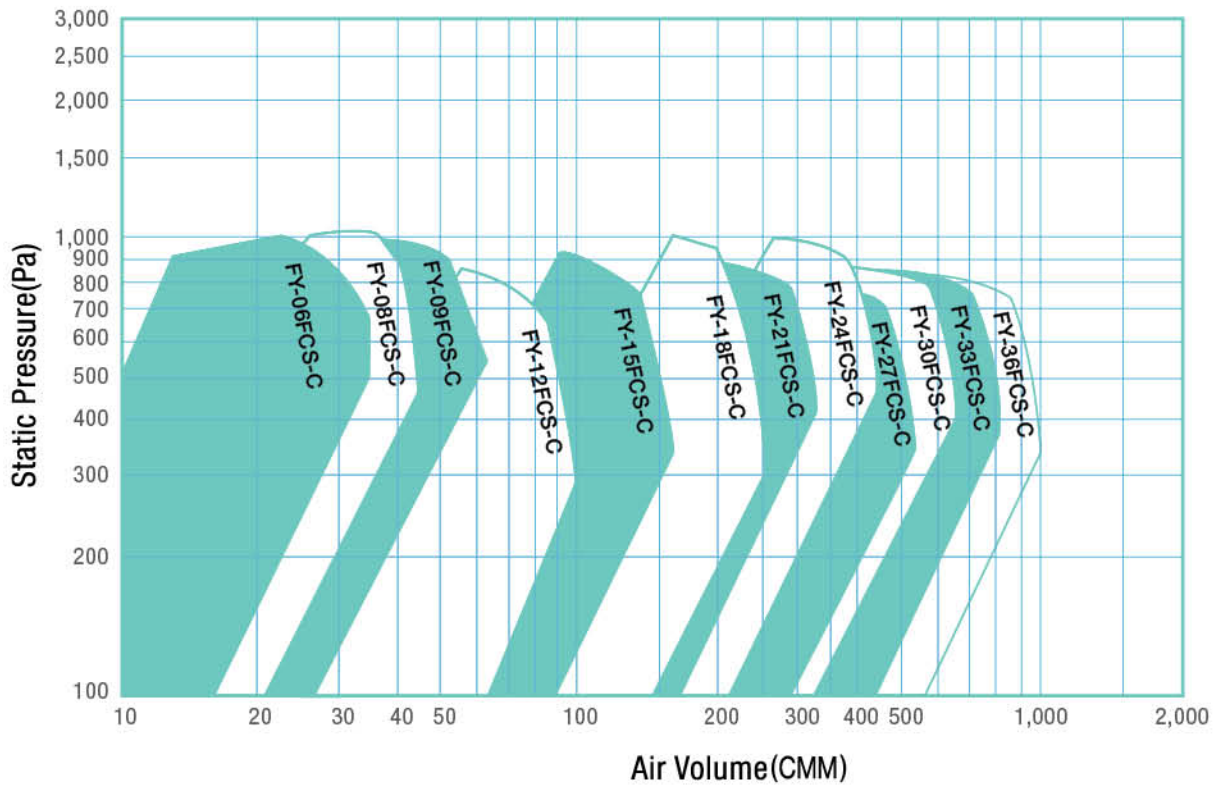

### Specifications

Model	SWSI	Rating Voltage	Phase	Wheel Diameter		Weight [Kg]	Model	SWSI	Rating Voltage	Phase	Wheel Diameter		Weight [Kg]
				[mm]	[inch]						[mm]	[inch]	
FY-06FCS-C	Floor-Mount	380V / 50Hz	3	160	6	17	FY-18FCS-C	Floor-Mount	380V / 50Hz	3	464	18	105
	Ceiling-Mount				160	6		14.5			Ceiling-Mount		464
FY-08FCS-C	Floor-Mount			202	8	19	FY-21FCS-C	Floor-Mount			529.6	21	145
	Ceiling-Mount			202	8	16.5		Ceiling-Mount			529.6	21	138
FY-09FCS-C	Floor-Mount			254	9	23	FY-24FCS-C	Floor-Mount			621.6	24	180
	Ceiling-Mount			254	9	20		Ceiling-Mount			621.6	24	170
FY-12FCS-C	Floor-Mount			302	12	42	FY-27FCS-C	Floor-Mount			686	27	285
	Ceiling-Mount			302	12	38	FY-30FCS-C	Ceiling-Mount			762	30	330
FY-15FCS-C	Floor-Mount			382	15	60	FY-33FCS-C	Floor-Mount			838	33	415
	Ceiling-Mount			382	15	55	FY-36FCS-C	Ceiling-Mount			915	36	490

### Forward Curved Multi-Blade Fan DWDI



Three Phase		
FY-12FCD-C	FY-21FCD-C	FY-30FCD-C
FY-15FCD-C	FY-24FCD-C	FY-33FCD-C
FY-18FCD-C	FY-27FCD-C	FY-36FCD-C

### Selection Chart

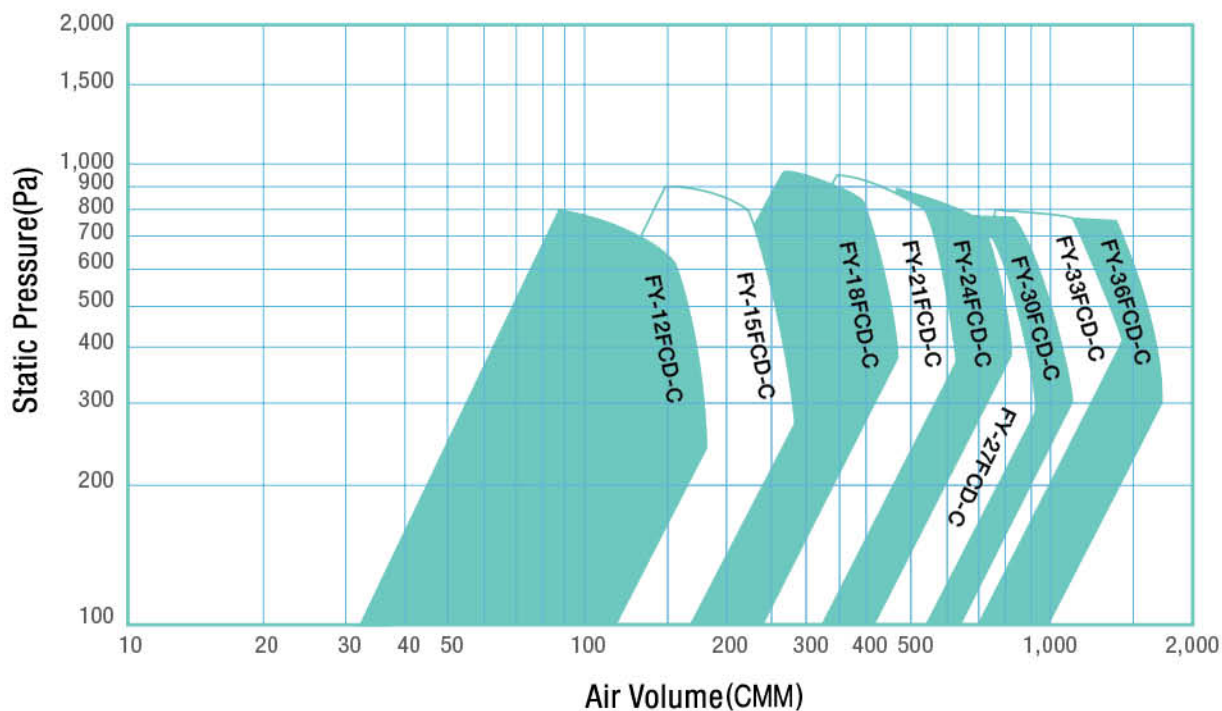

### Specifications

Model	DWDI	Phase	Rating Voltage	Wheel Diameter		Weight [Kg]
				[mm]	[inch]	
FY-12FCD-C	Floor-Mount	3	380V / 50Hz	302	12	85
FY-15FCD-C				382	15	110
FY-18FCD-C				464	18	160
FY-21FCD-C				529.6	21	230
FY-24FCD-C				621.6	24	300
FY-27FCD-C				686	27	420
FY-30FCD-C				762	30	500
FY-33FCD-C				838	33	620
FY-36FCD-C				915	36	730

### Backward Curved Blade Limit-Load Fan SWSI



Three Phase		
FY-12BCS-D	FY-21BCS-D	FY-30BCS-D
FY-15BCS-D	FY-24BCS-D	FY-33BCS-D
FY-18BCS-D	FY-27BCS-D	FY-36BCS-D

### Selection Chart

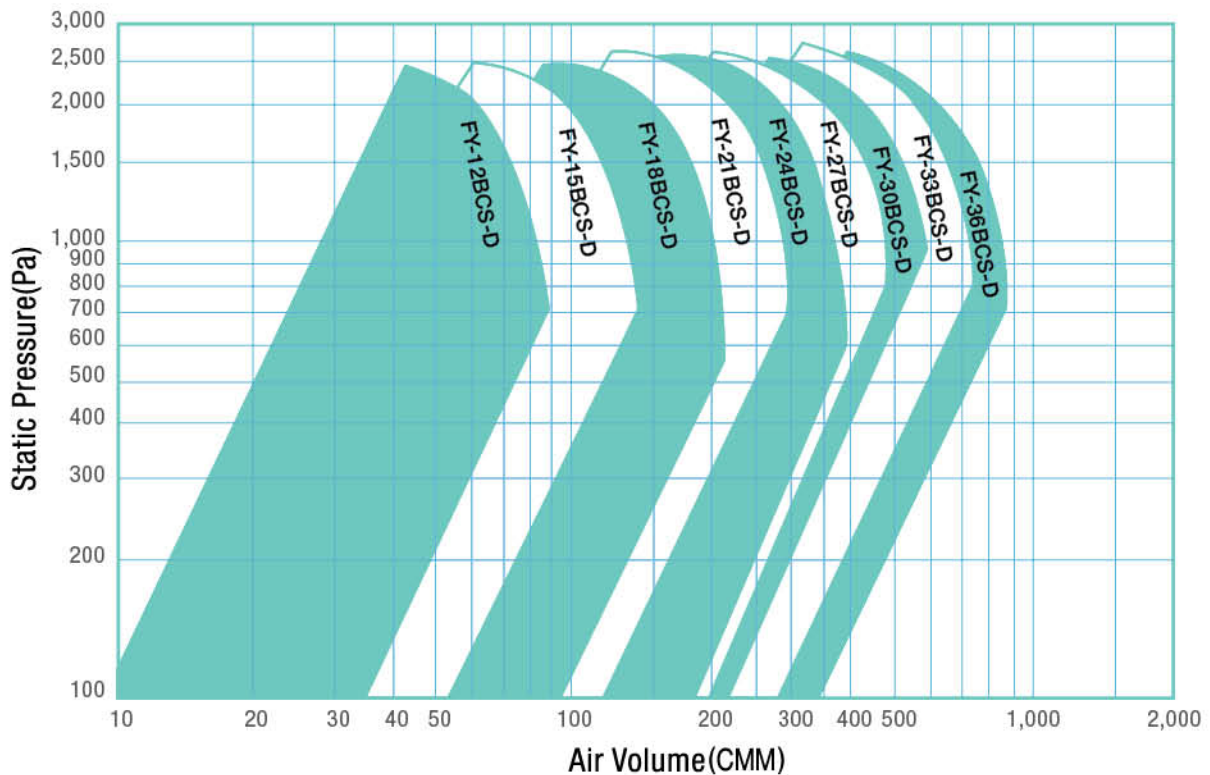

### Specifications

Model	SWSI	Phase	Rating Voltage	Wheel Diameter		Weight [Kg]
				[mm]	[inch]	
FY-12BCS-D	Floor-Mount	3	380V / 50Hz	310	12	75
FY-15BCS-D				390	15	90
FY-18BCS-D				467	18	115
FY-21BCS-D				545	21	160
FY-24BCS-D				623	24	205
FY-27BCS-D				701	27	310
FY-30BCS-D				778	30	360
FY-33BCS-D				856	33	460
FY-36BCS-D				934	36	560



### Backward Curved Blade Limit-Load Fan DWDI

Three Phase		
FY-12BCD-D	FY-21BCD-D	FY-30BCD-D
FY-15BCD-D	FY-24BCD-D	FY-33BCD-D
FY-18BCD-D	FY-27BCD-D	FY-36BCD-D

### Selection Chart

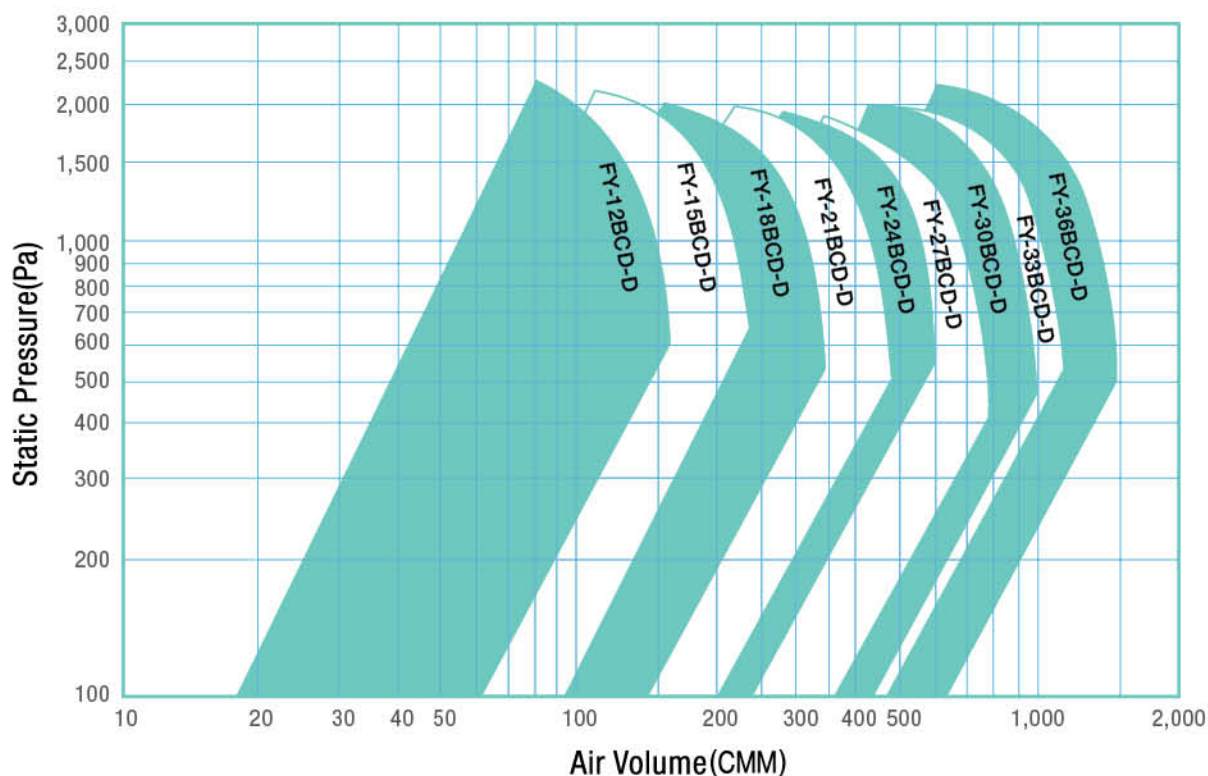

### Specifications

Model	DWDI	Phase	Rating Voltage	Wheel Diameter		Weight [Kg]
				[mm]	[inch]	
FY-12BCD-D	Floor-Mount	3	380V / 50Hz	310	12	90
FY-15BCD-D				390	15	115
FY-18BCD-D				467	18	170
FY-21BCD-D				545	21	235
FY-24BCD-D				623	24	300
FY-27BCD-D				701	27	490
FY-30BCD-D				778	30	570
FY-33BCD-D				856	33	720
FY-36BCD-D				934	36	890



### Selection Chart

Full Solidity

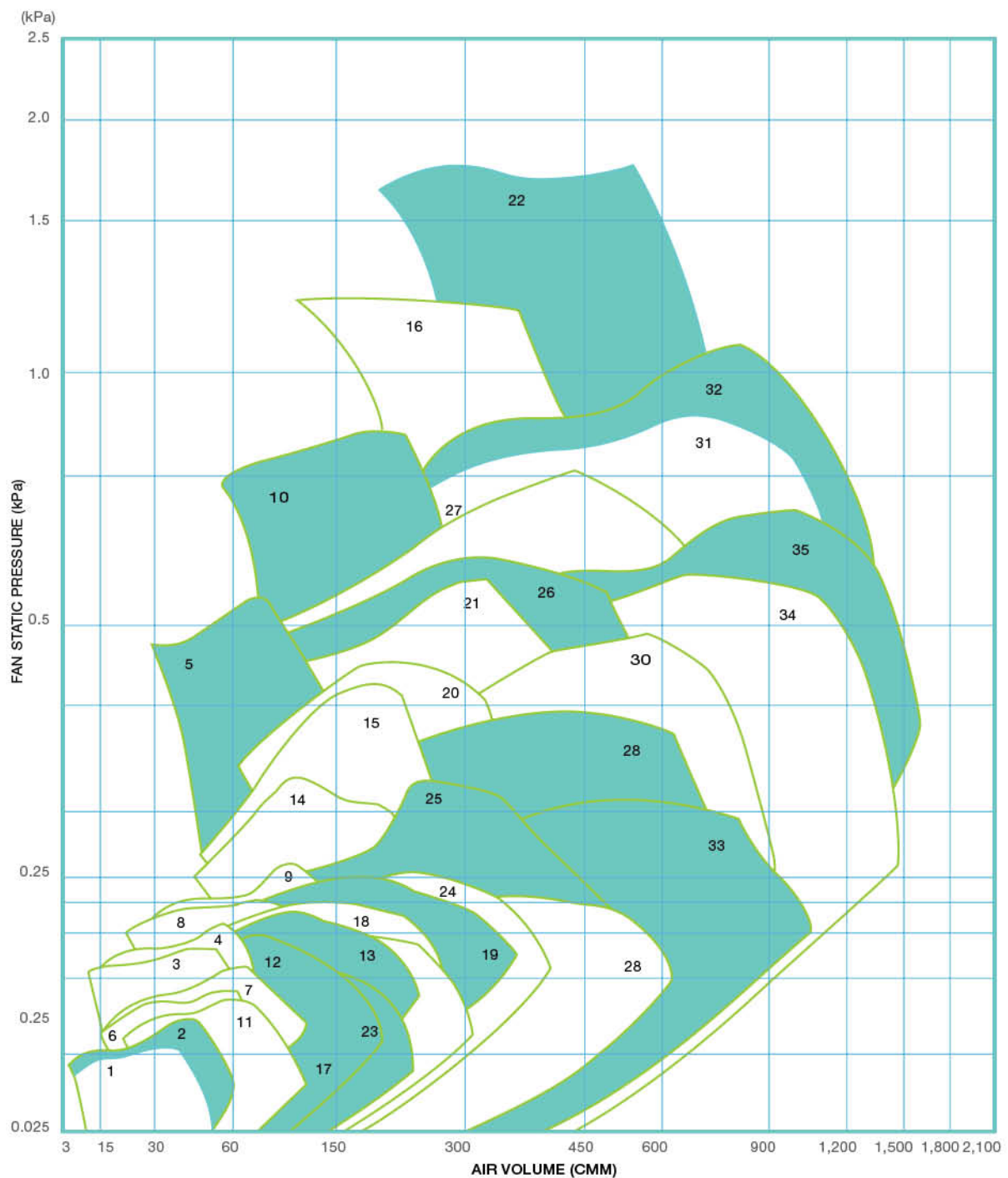



### Selection Chart

Partial Solidity

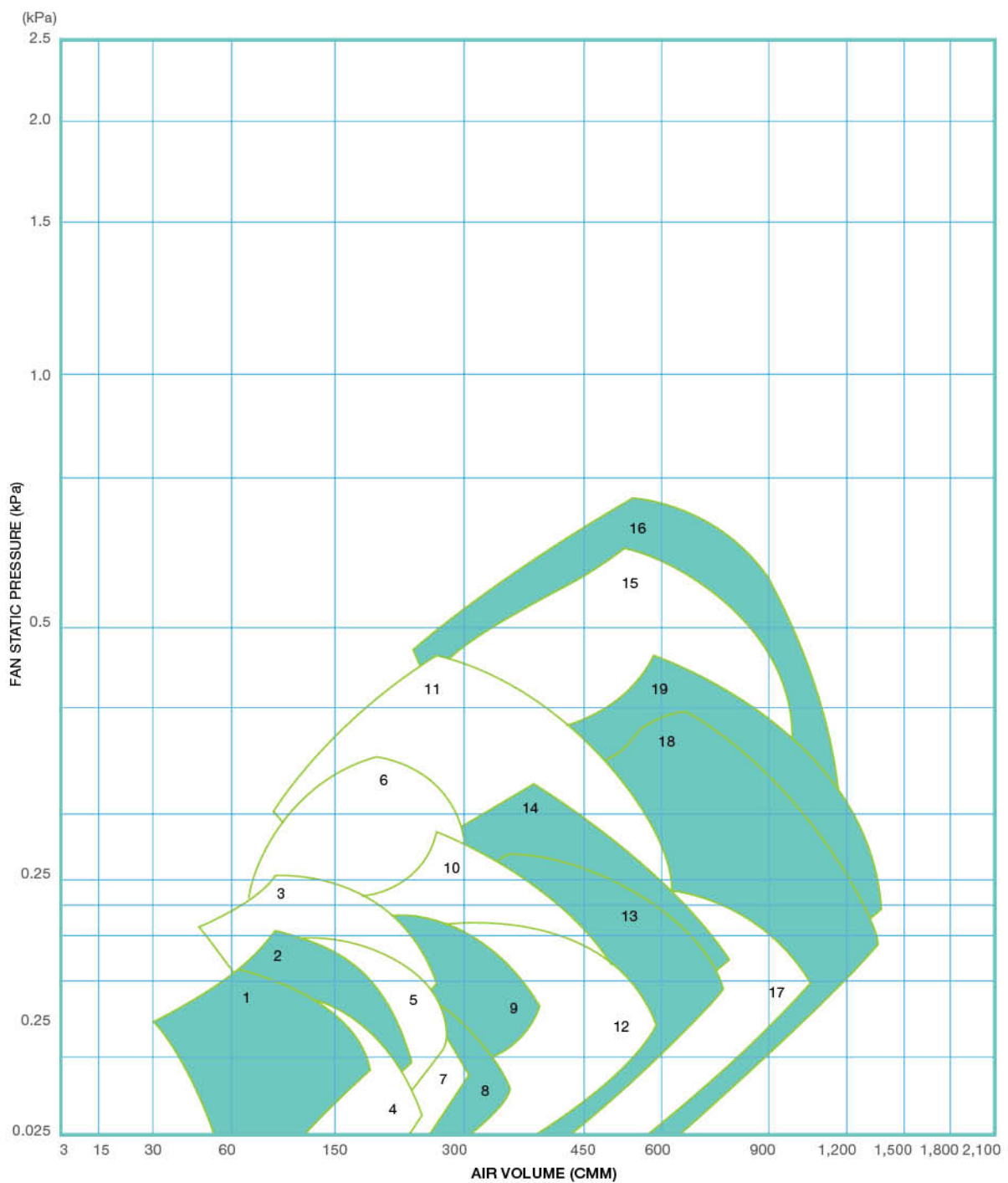

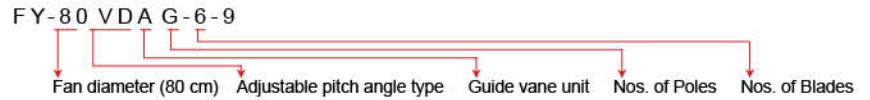

### Specification

Chart No	Model	Power Consumption [kW]	Fan Speed [R.P.M]	Pitch Angle	Diameter [mm]
1	FY-40VDA-6-7	0.2	960	4 - 36	400
2	FY-40VDAG-6-7	0.2	960	4 - 36	400
3	FY-40VDA-4-7	0.2 0.4	1,450	4 - 30 32 - 36	400
4	FY-40VDAG-4-7	0.2 0.4	1,450	4 - 24 26 - 34	400
5	FY-40VDA-2-9	1.5 2.2 3.7	2,900	4 - 24 26 - 34 36	400
6	FY-50VDA-6-7	0.2 0.4	960	4 - 32 34-36	500
7	FY-50VDAG-6-7	0.2 0.4	960	4 - 26 28-36	500
8	FY-50VDA-4-7	0.4 0.75 1.5	1,450	4 - 20 22-34 36	500
9	FY-50VDAG-4-7	0.4 0.75 1.5	1,450	4 - 18 20-26 28-36	500
10	FY-50VDAG-2-9	2.2 3.7 5.5 7.5	2,930	4 - 10 12-20 22-28 30-36	500
11	FY-60VDAG-8-9	0.2 0.4	730	4 - 28 30 - 36	600
12	FY-60VDAG-6-9	0.2 0.75	960	4 - 26 28 - 36	600
13	FY-60VDAG-6-9	0.4 0.75 1.5	960	4 - 20 22 - 28 30 - 36	600
14	FY-60VDAG-4-9	0.75 1.5 2.2	1,450	4 - 14 16 - 28 30 - 36	600
15	FY-60VDAG-4-9	1.5 2.2 3.7	1,450	4 - 22 24 - 26 28 - 34	600
16	FY-60VDA-2-9	5.5 7.5 11 15	2,950	8 - 10 12 - 24 16 - 22 24 - 30	600
17	FY-70VDAG-8-9	0.4 0.75	730	4 - 26 28 - 36	700
18	FY-70VDAG-6-9	0.75 1.5	960	4 - 22 24 - 36	700
19	FY-70VDAG-6-9	0.75 1.5 2.2 3.7	960	4 - 18 20 - 28 30 - 34 36	700
20	FY-70VDA-4-9	1.5 2.2 3.7 5.5	1,450	4 - 14 16 - 20 22 - 30 32 - 36	700
21	FY-70VDAG-4-9	1.5 2.2 3.7 5.5 7.5	1,450	4 - 10 12 - 16 18 - 22 24 - 28 30 - 34	700

### Full Solidity

Chart No	Model	Power Consumption [kW]	Fan Speed [R.P.M]	Pitch Angle	Diameter [mm]
22	FY-70VDA-2-10	11 15 18.5 22 30	2,950	6 - 8 10 - 14 16 - 18 20 22-28	700
23	FY-80VDA-8-9	0.75 1.5	730	4 - 26 28 - 36	800
24	FY-80VDA-6-9	1.5 2.2 3.7	960	4 - 22 24 - 30 32 - 36	800
25	FY-80VDAG-6-9	1.5 2.2 3.7 5.5	960	4 - 18 20 - 24 26 - 32 34-36	800
26	FY-80VDAG-4-9	2.2 3.7 5.5 7.5 11	1,470	4 - 8 10 - 16 18 - 24 26 - 30 32 - 36	800
27	FY-80VDAG-4-9	2.2 3.7 5.5 7.5 11 15	1,470	4 - 6 8 - 12 14 - 18 20 - 22 24 - 28 30 - 34	800
28	FY-100VDA-8-15	2.2 3.7	730	4 - 24 26 - 36	1,000
29	FY-100VDA-6-12	3.7 5.5 7.5 11	985	4 - 18 20 - 24 26 - 32 34 - 36	1,000
30	FY-100VDAG-6-12	3.7 5.5 7.5 11	985	4 - 14 16 - 20 22 - 24 26 - 30	1,000
31	FY-100VDA-4-12	5.5 7.5 11 15 18.5 22 30	1,470	4 - 6 8 - 10 12 - 26 18 - 20 22 - 24 26 - 28 30 - 36	1,000
32	FY-100VDAG-4-12	5.5 7.5 11 15 18.5 22 30	1,470	4 - 6 8 10 - 14 16 - 18 20 22 24 - 28	1,000
33	FY-120VDA-8-12	5.5 7.5 11	730	4 - 24 26-32 34 - 36	1,200
34	FY-120VDA-6-12	7.5 11 15 18.5 22	985	4 - 14 16 - 20 22 - 26 28 - 32 34 - 36	1,200
35	FY-120VDAG-6-12	7.5 11 15 18.5 22 30	985	4 - 12 14 - 16 18 - 22 24 26 - 28 30	1,200



### Specification

Chart No	Model	Power Consumption [kW]	Fan Speed [R.P.M]	Pitch Angle	Diameter [mm]
1	FY-60VDA-6-6	0.4 0.75	960	4 - 32 34 - 36	600
2	FY-60VDA-4-3	0.75 1.5	1,450	4 - 28 30 - 36	600
3	FY-60VDA-4-6	0.75 1.5 2.2	1,450	4 - 20 22 - 34 36	600
4	FY-70VDA-6-3	0.75	960	4 - 36	700
5	FY-70VDA-6-6	0.75 1.5	960	4 - 28 30 - 36	700
6	FY-70VDA-4-6	1.5 2.2 3.7	1,450	4 - 18 20 - 26 28 - 36	700
7	FY-80VDA-8-6	0.75 1.5	730	4 - 32 34 - 36	800
8	FY-80VDA-6-3	1.5	960	4 - 36	800
9	FY-80VDA-6-6	1.5 2.2	960	4 - 36 30 - 36	800
10	FY-80VDA-4-3	2.2 3.7 5.5	1,470	4 - 22 24 - 30 32 - 36	800
11	FY-80VDA-4-6	2.2 3.7 5.5 7.5	1,470	4 - 14 16 - 22 24 - 30 32 - 36	800

### Partial Solidity

Chart No	Model	Power Consumption [kW]	Fan Speed [R.P.M]	Pitch Angle	Diameter [mm]
12	FY-100VDA-8-8	2.2 3.7	730	4 - 32 34 - 36	1,000
13	FY-100VDA-6-6	3.7 5.5	985	4 - 28 30 - 36	1,000
14	FY-100VDA-6-8	3.7 5.5 7.5	985	4 - 24 26 - 32 34 - 36	1,000
15	FY-100VDA-4-6	5.5 7.5 11 15 18.5	1,470	4 - 12 14 - 18 20 - 24 26 - 32 34 - 36	1,000
16	FY-100VDA-4-8	5.5 7.5 11 15 18.5 22	1,470	4 - 10 12 - 14 16 - 22 24 - 28 30 - 32 34 - 36	1,000
17	FY-120VDA-8-8	5.5 7.5	730	4 - 32 34 - 36	1,200
18	FY-120VDA-6-6	7.5 11 15	985	4 - 22 24 - 30 32 - 36	1,200
19	FY-120VDA-6-8	7.5 11 15 18.5	985	4 - 20 24 - 26 28 - 34 36	1,200

Fractional solidities for fan sizes 24" (600 mm) to 48" (1200 mm). Maximum efficiencies at relatively low pressures are obtained by varying the solidity (number of blades) of a fan which enables it to work at the most efficient part of its performance characteristic.

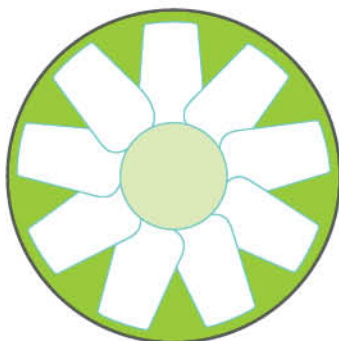

e.g. FY-80VDA-6-9

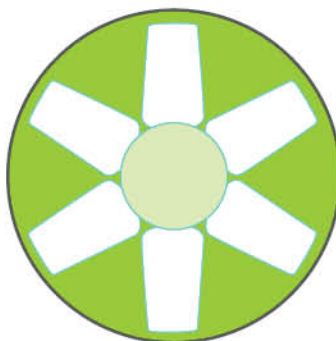

e.g. FY-80VDA-6-6

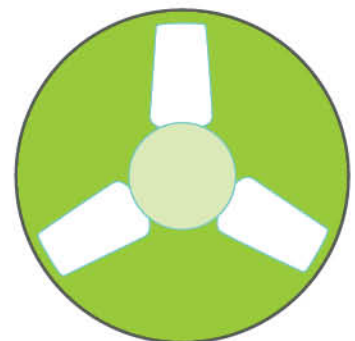

e.g. FY-80VDA-6-3





# Air Curtains

Introduction

41

Air Curtains

42





Doors of a shop need to be opened frequently to let people pass through. However, open door allows air leaks to outside that increases energy consumption of air conditioners. By using air curtain, an invisible air screen will build up to minimize air exchange between the air at outside and indoor.

### Improved Functionality and Workability

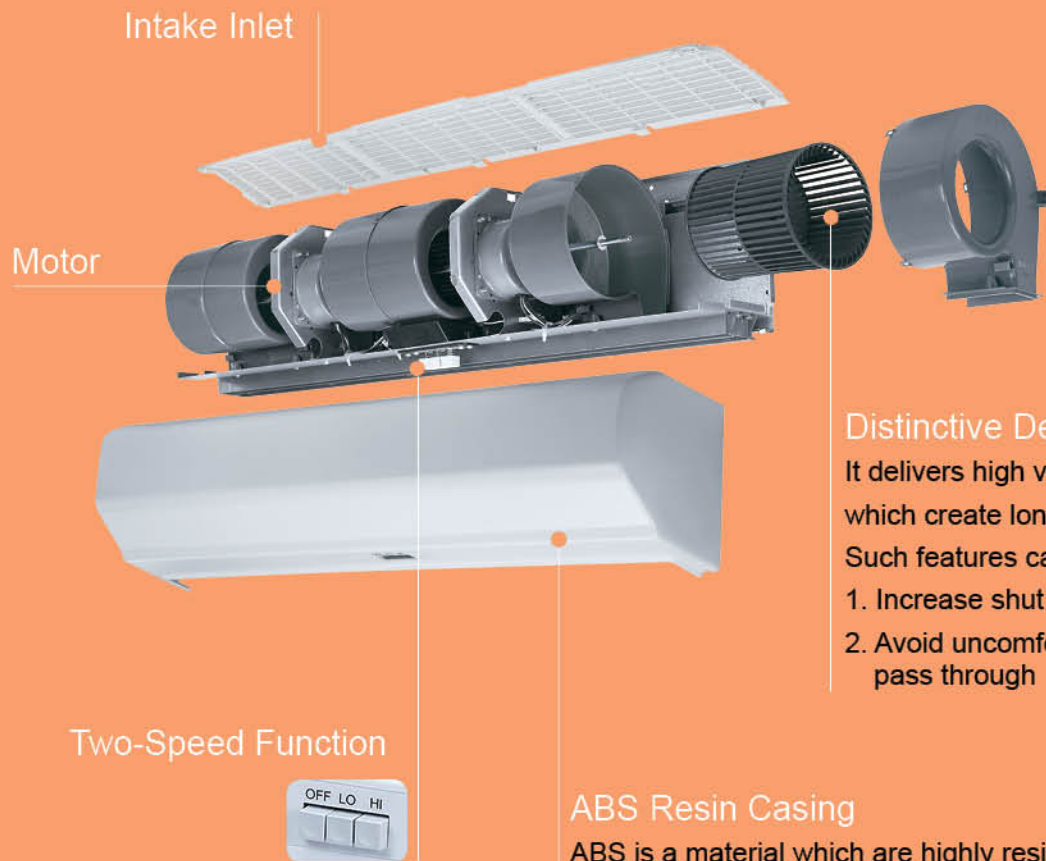

**Distinctive Design of Sirocco Fan**  
It delivers high velocity and thin air flow which create longer reach and narrow diffusion. Such features can

1. Increase shut out ability and
2. Avoid uncomfortable feelings when you pass through

**ABS Resin Casing**  
ABS is a material which are highly resistant to rust and with high bending flexibility which make the outlook more streamline. It provides a simple design that suits for all interiors.

## Advantages of Panasonic Air Curtain

### High Air Velocity

The high pressure produced by sirocco fan delivering a powerful jet of air from the air outlet. Thus maximizes the effect of the air curtain.

$$V_s = A \times V_x$$

$V_s$  : Shut-out penetrating velocity (m/s)

$V_x$  : Central air velocity (m/s) at distance X(m) from the air outlet

A : Constant

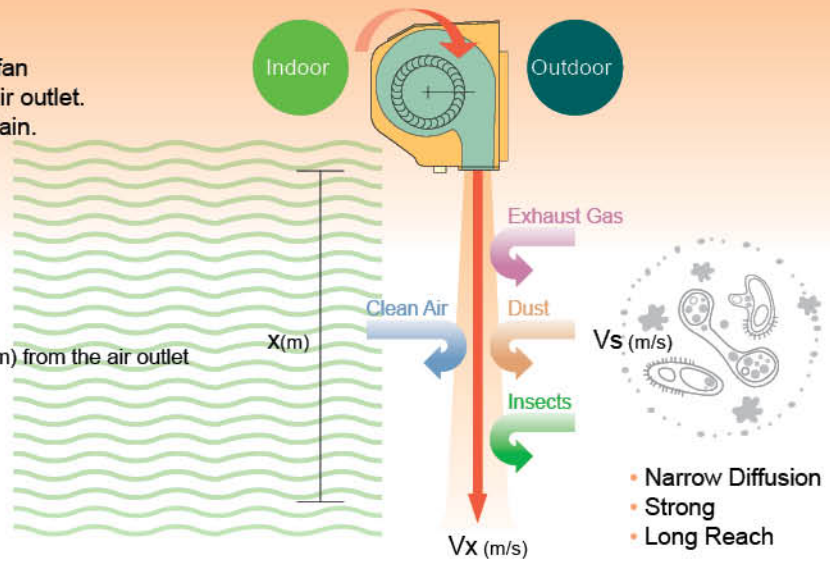

The above illustration shows an effect of air curtain as sensuous image.

### Low Consumption

High efficient motors are adopted to ensure low power consumption by reducing up to 35%.  
(Compared with previous 3 meter models)

### Low Noise

The quiet sirocco fan and ABS resin casing have reduced the noise level by an average of 10dB(A) compared with conventional models.

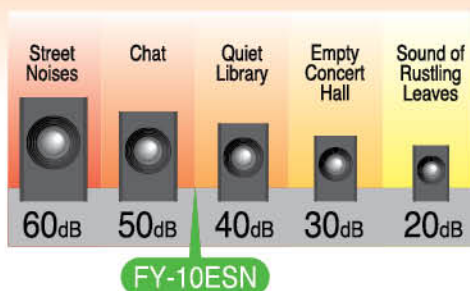

### Easy Maintenance

The casing can be removed simply by unscrew 4 bolts. The whole set can be detached from wall to remove dust from sirocco fan for cleaning.

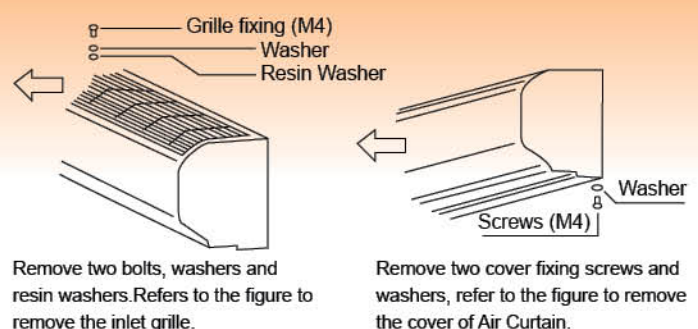

Remove two bolts, washers and resin washers. Refer to the figure to remove the inlet grille.

Remove two cover fixing screws and washers, refer to the figure to remove the cover of Air Curtain.

# Air Curtains

## Assumptions:

1. The Area of typical shop is 23.49 sq.m
2. 1 set of Panasonic large capacity air conditioner (model no. CS-D24DB4H5) is installed inside the shop
3. 2 sets of Panasonic Air Curtain (model no. FY-12ELN) are installed at the entrances

	Temperature (°C)	Humidity (%)
Indoor	23	55
Outdoor	35	95

5. Calculation is based on HK electricity charge : HK\$1/ kw
6. Operating hours of air conditioner and air curtain in the shop is 450 per month. (15 hours x 30 days)

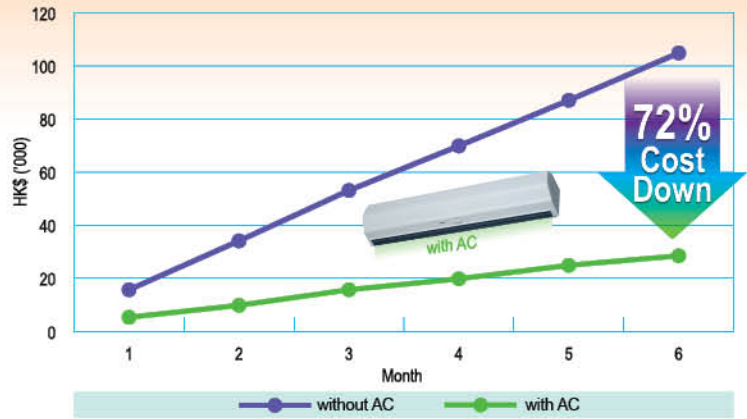

**Result** Using an air conditioner together with air curtains can save energy consumption up to 72%

### Notes:

- 1) Energy lost of air curtain is not included
- 2) Calculated at 0 m/s outside wind
- 3) Values are for reference only. Results will vary subject to outside wind, pressure balance of indoor and outdoor, etc.

## Model Selection

The air curtain comes in six models. Select your model according to the installation site, usage area and required capacity.

Length of unit	Air velocity chart (m/s) Maximum value at HI speed 50Hz
900mm (3 feet)	
FY-10ESN	
1,200mm (4 feet)	
FY-10ELN	

Length of unit	Air velocity chart (m/s) Maximum value at HI speed 50Hz
900mm (3 feet)	
FY-12ESN	
1,200mm (4 feet)	
FY-12ELN	

Length of unit	Air velocity chart (m/s) Maximum value at HI speed 50Hz
900mm (3 feet)	
FY-14ESN	
1,200mm (4 feet)	
FY-14ELN	

▼ Efficient distance

The velocity characteristics were measured in a testing room free from the influence of surrounding walls and outside wind. Outside wind, air flow from air conditioners, use of ventilating equipment, etc., significantly lower the shielding effectiveness. Take these factors into consideration, it is recommended to select the one rank bigger model for better function.

## Shut-Out Ability

An air curtain's shut-out ability is determined by the air velocity at the center of its airflow. The powerful discharge of air curtains enables them to maintain a high level of air velocity for the curtain's efficient distance, resulting in superior shut-out ability.

# Specifications

Model	Rating Voltage	Air Volume		Power Consumption [w]	Outlet Velocity [m/s]	Noise [dB(A)]	Current [A]	Weight [kg]	Length [mm]
		[CMH]	[l/s]						
FY-10ESN	Hi	750	208	72	13	46	0.40	12	900
	Lo	630	175	62	11.1	42	0.29		
FY-10ELN	Hi	1,000	278	96	13.1	46	0.54	14	1,200
	Lo	830	230	74	11	42	0.35		
FY-12ESN	Hi	1,050	292	176	16.9	55	0.82	13	900
	Lo	960	267	155	15.8	50	0.69		
FY-12ELN	Hi	1,420	394	224	17	56	1.04	15	1,200
	Lo	1,320	367	200	15.8	51	0.90		
FY-14ESN	Hi	1,340	372	257	21.9	62	1.14	13	900
	Lo	1,168	324	218	19.1	59	0.99		
FY-14ELN	Hi	1,867	518	333	22.5	63	1.52	15	1,200
	Lo	1,668	463	290	20.1	61	1.32		

Note : The values in specification tables are representative characteristic value at 220V 50Hz and the ambient temperature of 20°C.

The noise values were measured at an angle of 40° Below the air outlet, from a distance of 1.5 meters inside the room. The outlet velocity shows maximum value.

# Dimensions

unit : mm

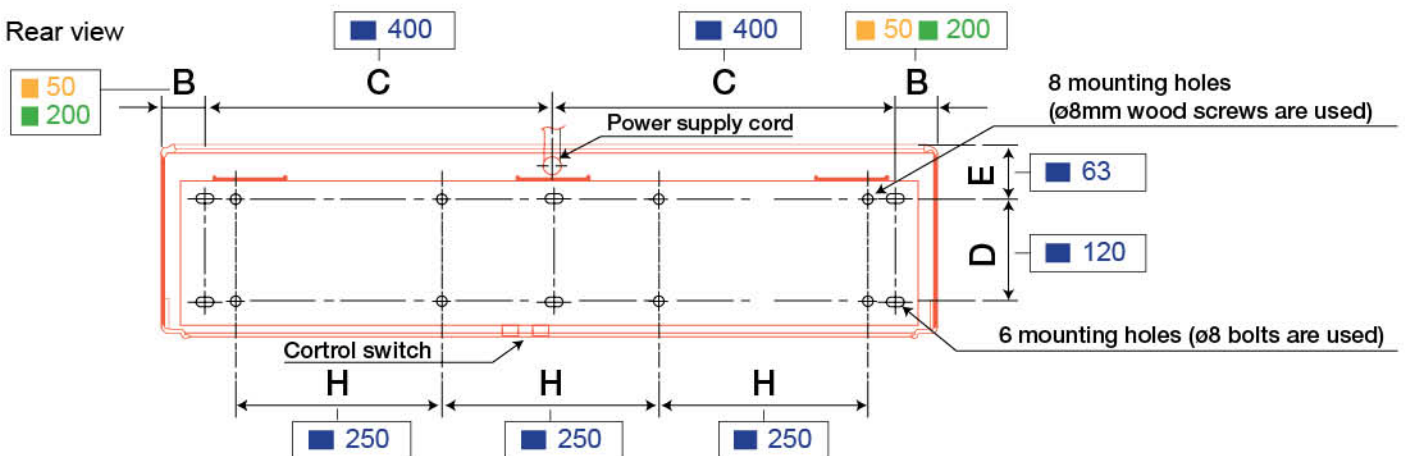
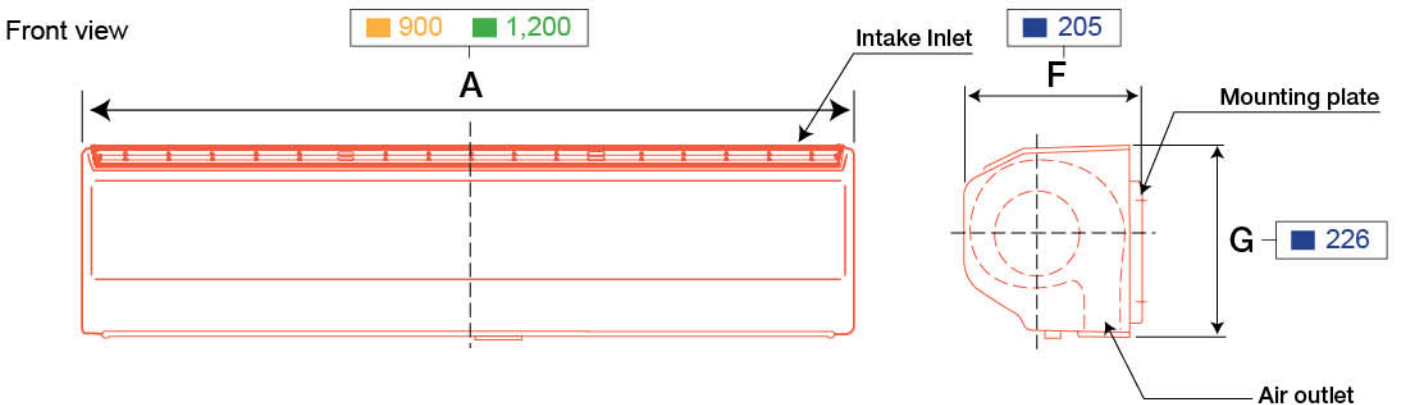

■ FY-10ESN FY-12ESN FY-14ESN    
 ■ FY-10ELN FY-12ELN FY-14ELN    
 ■ All models

## Installation Method

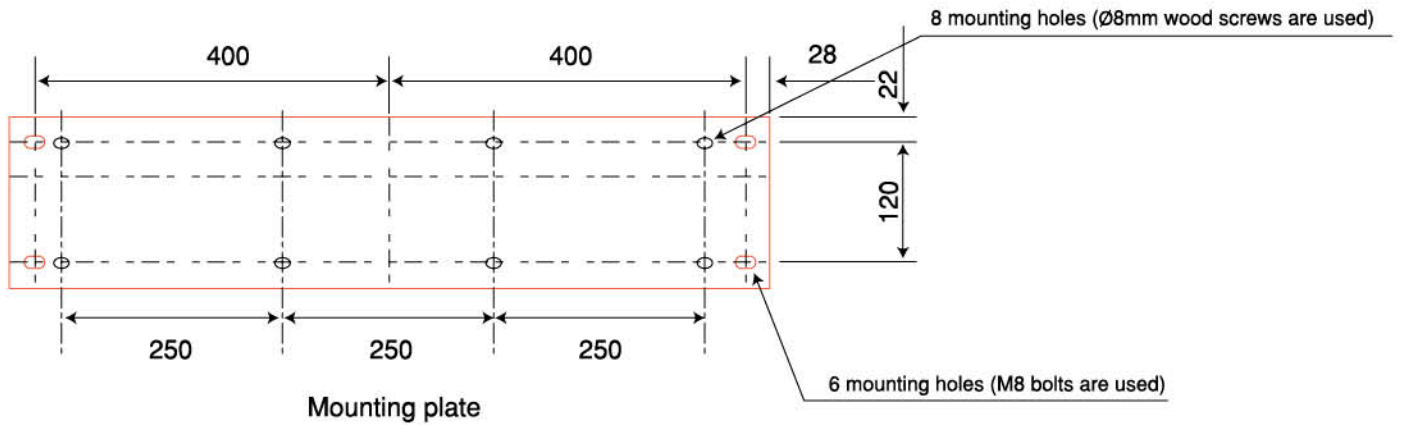

### 1 Mounting on Concrete

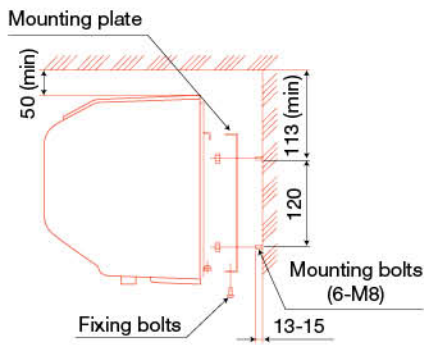

Fix the mounting plate tightly with washers, spring washers and nuts

### 2 Mounting on Wooden Frame

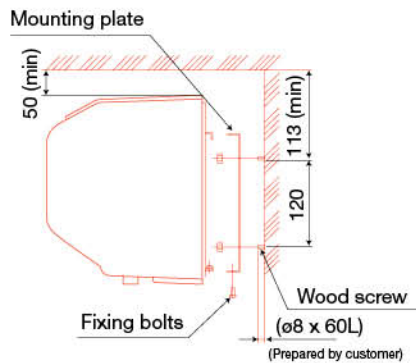

If mounting to a wooden frame, you may need to use a reinforcing material to ensure a secure installation

### 3 Mounting on Steel Hanger

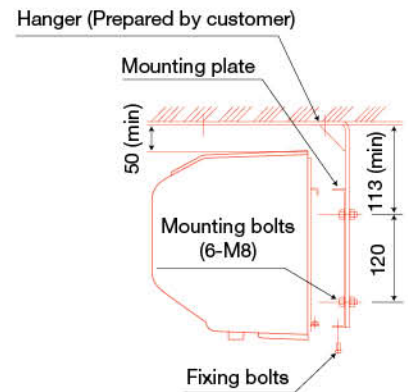

If using customer-provided hangers, use six M8 bolts, washers, spring washers and nuts to fix the unit tightly

min = minimum

## Electric Work

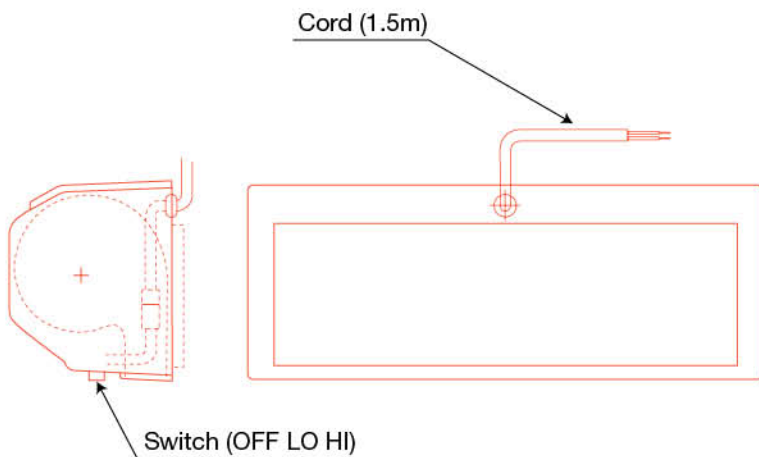

### Connection Diagram

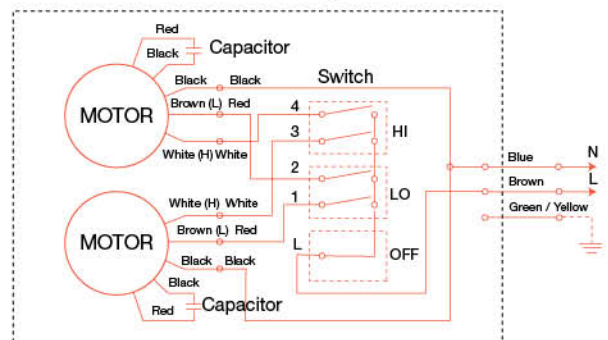



# ACCESSORIES



Pipe Hood

47



Vent Cap

48

## For Ceiling Mount Ventilating Fans & Air Moving Equipment



With Net

Without Net

FV-MGX100P FV-MGX150P

FV-MCX100P FV-MCX150P

- Round type pipe hood
- 2.5x2.5mm net equipped to keep out ingress of small particles (FV-MGX100P, FV-MGX150P Only)
- High strength stainless steel adopted
- Coated with metallic silver paint prevent oxidation of material
- 3 pieces of spring clip allow easy connection of duct or pipe
- Applicable to diameter 100/150mm duct or pipe
- It is recommended to use with net type for intake purpose

### Dimensions

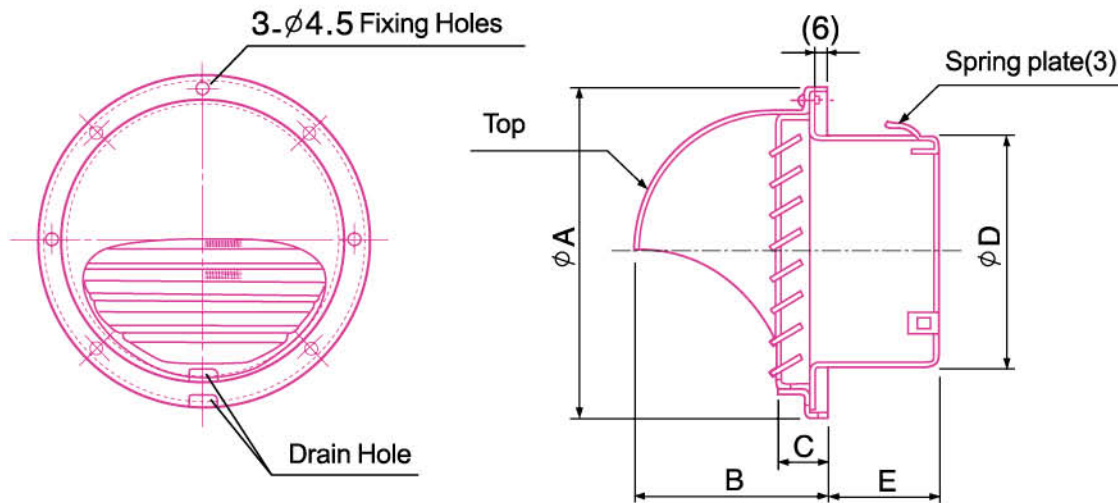

Model	A	B	C	D	E	Diameter of Applicable Pipe [mm]	Net Hole [mm]
FV-MGX100P	141	79	20	97	48	100	2.5 x 2.5
FV-MGX150P	190	106	23	147	53	150	2.5 x 2.5
FV-MCX100P	141	79	20	97	48	100	-
FV-MCX150P	190	106	23	147	53	150	-



## For Ceiling Mount Ventilating Fans & Air Moving Equipment



With Net

FV-VGX100P    FV-VGX150P



Without Net

FV-VCX100P    FV-VCX150P

- Round type vent cap
- 2.5x2.5mm net equipped to keep out ingress of small particles (FV-VGX100P, FV-VGX150P Only)
- High strength stainless steel adopted
- Coated with metallic silver paint prevent oxidation of material
- 3 pieces of spring clip allow easy connection of duct or pipe
- Applicable to diameter 100/150mm duct or pipe
- It is recommended to use with net type for intake purpose

### Dimensions

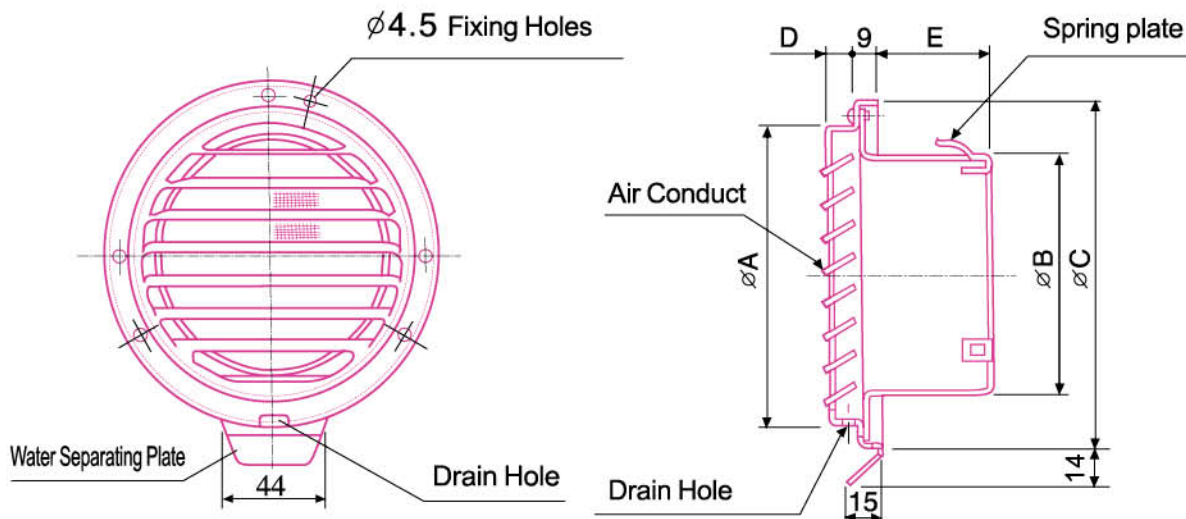

Model	A	B	C	D	E	Diameter of Applicable Pipe [mm]	Net Hole [mm]
FV-VGX100P	120	97	145	13	47	100	2.5 x 2.5
FV-VGX150P	169	147	195	18	52	150	2.5 x 2.5
FV-VCX100P	120	97	145	13	47	100	-
FV-VCX150P	169	147	195	18	52	150	-



### Ventilating Fan - Ceiling Mount Type

Park Hotel, Tsim Sha Tsui  
Royal View Hotel, Ting Kau  
Vision City, Tsuen Wan  
Rambler Oasis Hotel, Tsing Yi  
Metro Park Hotel, Kowloon  
Lake Silver, Wu Kai Sha  
Palazzo, Sha Tin

The Dynasty, Tsuen Wan  
Festival City, Tai Wai  
Pun Tak Building, Causeway Bay  
No.12 Broadwood Road  
Emerald Green, Yuen Long  
Star River, Macau

### Ventilating Fan - High Pressure Industrial Type

Stanley Ho Sports Centre, HKU  
OTIS  
Tunnel CLP Power Station, Tseung Kwan O  
The Great Hill, Sha Tin

Lohas Park, Tseung Kwan O  
International Christine School HK, Sha Tin  
Fujitec Lifts

### Air Moving Equipment - Low-noise Type Cabinet Fan

Park Island, Ma Wan  
MGM Grand Hotel, Macau  
Peak One, Sha Tin  
The Vineyard, Yuen Long  
W-Hotel, Kowloon Station  
The Harbour View Place, Kowloon Station  
Le Point, Tin Keng Leng  
Coastal Skyline, Tung Chung  
One Central Macau Residences, Macau  
Langham Hotel, Tsim Sha Tsui  
Greenview Villa, Tsing Yi

The Apex, Kwai Chung  
Yoho Town, Yuen Long  
Floriant Rise  
Valais  
No. 5-11, South Bay Road, Repulse Bay  
6 Shiu Fai Terrace  
Century Gateway, Tuen Mun  
Double Cove, Ma On Shan  
Billionnaire Avant, Kowloon City  
Riva, Yuen Long  
Nova City, Macau

### Air Moving Equipment - Mini Sirocco Fans

Royal Park Hotel, Sha Tin  
Schindler Lifts  
Green Code, Fanling

PCCW Tower  
Royal Garden Hotel

### Air Curtain

2008 Olympic Equestrian Venue, Sha Tin  
Margaret Hospital  
Asia Air Freight Terminal Expansion  
HAECO

The Hong Kong Community College, Poly U  
Mong Kok East Station  
Link Management  
Mannings

# Panasonic®

\*Unit Conversion: 1 CMH = 0.2777 l/s  
\*Specifications are subject to change without prior notice  
\*Actual colors may slightly vary from those shown.  
\*Please refer to the instruction manual during installation.



**Sole Agent :**

**Shun Hing Electric Works And Engineering Co., Ltd.**

Room 601, East Ocean Centre, 6/F., 98 Granville Road,  
Tsimshatsui East, Kowloon, H.K.

Tel : (852) 2861 2767

Fax : (852) 2865 6706

Website : [www.shew.com.hk](http://www.shew.com.hk)

E-mail : [shew@shunhinggroup.com](mailto:shew@shunhinggroup.com)

**Maintenance and Repair Service :**

**Shun Hing Electric Service Centre Ltd.**

19/F., Shun Hing Centre, 8 Shing Yiu Street,  
Kwai Chung, N.T., H.K.

Tel : (852) 2406 5666 Fax : (852) 2408 0316

Website : [www.shunhing-service.com](http://www.shunhing-service.com)

CAT-PAM1404

Printed in Hong Kong

04.14